



Grandstream Networks, Inc.

GXV3175

IP Multimedia Phone



GXV3175 User Manual

Index

WELCOME	6
<i>GXV3175 OVERVIEW</i>	6
PRODUCT OVERVIEW	8
INSTALLATION	11
EQUIPMENT PACKAGING	11
<i>SAFETY COMPLIANCES.....</i>	11
<i>WARRANTY</i>	12
CONNECTING THE GXV3175 IP MULTIMEDIA PHONE.....	12
<i>WALL MOUNT.....</i>	13
<i>PHONE STAND.....</i>	13
<i>CONNECTING THE GXV3175 IP MULTIMEDIA PHONE</i>	14
<i>MAKING THE FIRST CALL WITH IPVIDEOTALK SERVICE</i>	14
USING THE GXV3175 IP MULTIMEDIA PHONE.....	17
LCD.....	17
MULTIPLE SIP ACCOUNTS AND LINES.....	21
HANDSET, SPEAKER AND HEADSET MODE.....	23
MAKING A CALL.....	23
DURING CALLS	26
<i>ANSWERING CALLS</i>	26
<i>CALL FUNCTION OPTIONS.....</i>	28
<i>CALL HOLD.....</i>	29
<i>CALL TRANSFER</i>	30
<i>3-WAY CONFERENCE</i>	32
<i>VOICEMAIL (MESSAGE WAITING INDICATION)</i>	33
<i>MUTE</i>	33
KEYPAD INPUT.....	33
CALL FEATURES	35
GXV3175 WEB CONFIGURATION INTERFACE.....	37
ACCESSING THE WEB CONFIGURATION PAGES.....	37
DEFINITIONS	38

<i>STATUS PAGE DEFINITIONS</i>	38
<i>ADVANCED SETTINGS PAGE DEFINITIONS</i>	39
<i>MAINTENANCE PAGE DEFINITIONS</i>	42
<i>SIP ACCOUNT CONFIGURATION PAGE DEFINITIONS</i>	48
SAVING THE CONFIGURATION CHANGES.....	55
REBOOTING FROM REMOTE LOCATIONS.....	55

LCD MENU AND FEATURES 56

CONTACTS.....	56
CALL HISTORY	59
MESSAGES.....	59
SOCIAL NETWORKS	63
<i>GOOGLE VOICE</i>	63
BROWSER	66
MUSIC.....	68
<i>INTERNET RADIO</i>	68
<i>LAST.FM</i>	69
VIDEO	71
<i>YOUTUBE</i>	71
<i>MEDIA PLAYER</i>	73
<i>MOVIE TRAILER</i>	75
PHOTO	77
<i>PHOTO ALBUM</i>	77
<i>WORLD PHOTO</i>	78
<i>PHOTO VIEWER</i>	79
<i>SLIDE SHOW</i>	81
NEWS	82
<i>NEWS VIDEOS</i>	82
TOOLS.....	83
<i>FILE MANAGER</i>	83
<i>ALARM CLOCK</i>	84
<i>CALENDAR</i>	85
<i>IP2LOCATION</i>	87
<i>CALCULATOR</i>	88
SYSTEM SETTINGS	90
<i>ACCOUNT SETTINGS</i>	90
<i>NETWORK SETTINGS</i>	91
<i>TIME SETTINGS</i>	94
<i>DISPLAY</i>	95
<i>MAINTENANCE</i>	96
<i>CAMERA</i>	98

CALL FEATURES.....	99
VIDEO	100
SCREEN SAVER	101
BACKGROUND	102
TONES.....	102
LANGUAGE	104
SYSTEM INFO.....	105
PIP	106
DESKTOP WIDGETS	106
WORLD CLOCK.....	102
CURRENCY	104
NEWS VIDEOS	102
STOCK.....	104
WEATHER	102
RSS NEWS.....	104
CONTACTS	102
INTERNET RADIO	104
SOFTWARE UPGRADE.....	116
UPGRADE VIA MENU.....	116
UPGRADE VIA WEB BROWSER CONFIGURATION PAGE.....	116
NO LOCAL TFTP SERVERS.....	116
RESTORE FACTORY DEFAULT SETTINGS.....	118
RESTORE TO FACTORY DEFAULT SETTINGS VIA LCD MENU	118
RESTORE TO FACTORY DEFAULT SETTINGS VIA THE WEB INTERFACE	118
EXPERIENCING THE GXV3175 MULTIMEDIA PHONE	119

TABLE OF TABLES
GXV3175 USER MANUAL

Table 1 :Key Features	8
Table 2: GXV3175 Hardware Specification.....	8
Table 3: GXV3175 Technical Specifications.....	8
Table 4: GXV3175 Ports and Interface	12
Table 5: LCD Icon Definition.....	20
Table 6: GXV3175 Dialpad Definition.....	22
Table 7: GXV3175 Call Function Description.....	29
Table 8: GXV3175 Keypad Definition.....	35
Table 9 :GXV3175 Call Features	35
Table 10: GXV3175 Audio/Video Codec Feature Code	35

WELCOME

Thank you for purchasing Grandstream GXV3175 IP Multimedia Phone. GXV3175 IP Multimedia Phone represents the future in personal IP multimedia communication as the ultimate desktop multimedia phone. You will experience a brand-new exploration with GXV3175's 7" touch screen color LCD, plug-and-play access to free real-time video/voice call, always-on Internet web entertainment and social networking applications.

This user manual is designed to help you configure and manage GXV3175 IP Multimedia Phone. Besides demonstrating how to install the unit with ease, this manual will explain how to fully utilize the entire phone's voice and video call features like conference call, direct IP call as well as explore all the built-in feature-rich multimedia applications such as YouTube, Google Voice, Flickr and more.

GXV3175 OVERVIEW

The GXV3175 is an ideal desktop IP multimedia phone highlighting 7" touch screen color LCD, tilt capable 1.3M CMOS camera, integrated Wifi, comprehensive auxiliary ports, feature-rich web applications with novel streamline design and modeling. It supports a high quality selection of audio codecs and is compatible with the H.264/H.263/H.263+ video codec. The advanced telephony and video features, interoperability with 3rd party SIP products and ease of use make it an innovative and unique IP multimedia device for both enterprise and consumer users.

Once the GXV3175 is plugged into the broadband Internet connection, you can begin to make video calls with impressive clarity and enjoy other features of the multimedia phone including:

- Integrated web browser for one-touch access to personalized RSS feeds of real-time online information services (news videos, stock and currency updates, weather forecasts and etc.)
- Access to thousands of Internet radio stations and popular online music networks such as Last.fm
- Access to social networking sites such as Google Voice and web photo albums like Yahoo Flickr
- Access to streaming Internet entertainment sites including YouTube and Movie Trailer
- Access to build-in games featuring the touch screen operation
- Digital Photo Frame
- Full duplex speakerphone
- Ability to project video onto TV

CAUTION: Changes or modifications to this product not expressly approved by Grandstream, or operation of this product in any way other than as detailed by this User Manual, could void your manufacturer warranty.

- *This document is subject to change without notice. The latest electronic version of this user manual is available for downloading here:*
http://www.grandstream.com/support/gxv_series_phone/gxv3175/documents/gxv3175_usermanual_english.pdf
- *Reproduction or transmittal of the entire or any part, in any form or by any means, electronic or print, for any purpose without the written permission of Grandstream Networks, Inc. is not permitted.*

PRODUCT OVERVIEW

Table 1: Key Features

Open Compatible Standards	SIP 2.0, TCP/IP/UDP, RTP/RTCP, HTTP/HTTPS, ARP/RARP, ICMP, DNS (A record and SRV), DHCP, PPPoE, TFTP, NTP.
Interfaces	2 x 10/100Mbps Ethernet Ports with integrated PoE, 2 x USB (2.0) port, 3.5mm stereo headset port, SD Card slot, built-in WiFi(b/g/n).
Extraordinary Audio Quality	Advanced DSP for audio, Silence Suppression, VAD, CNG, AEC and AGC.
Extraordinary Video Quality	Real-time video H.263/H.263+ and H.264 codec even when operating under low bandwidth (32kbps-1Mbps).
Advanced Video Features	7" resistive touch screen LCD with 800 x 480 resolution, 45 degree rotating lens (perpendicular), Advanced VGA lens, auto focus, auto exposure, zoom in and zoom out (2x optical 2x digital) , Camera Block, PIP(Picture-in-Picture) and still picture capture/store.
Application Features	<ul style="list-style-type: none"> - Traditional audio features: Caller ID, Call Waiting, Call Holding, Call Transfer, Three-way Conference, Do-Not-Disturb, Mute, Automatic dial. - Application features: Built-in Web Browser, RSS News, Weather Forecast, Internet Radio, Media Player, Picture Viewer, Games, Calculator, Alarm clock, File Manager, Youtube, Google Voice and etc.

Table 2: GXV3175 Hardware Specification

Ethernet Port	Dual switched 10M/100M auto-sensing Ethernet ports.
LCD	800 x 480 resistive touch screen LCD.
Camera	Tilt Capable 1.3M pixel CMOS camera with privacy shutter (VGA).
Auxiliary Ports	RCA Type Stereo and Media output port, 3.5mm stereo headset port, 2 x USB port, SD card slot.
Exterior	Black ABS plastic, Flat Panel with 1 x home button, two-angle stand.
Universal Power Supply	Input: 100-240V AC Output: 12V DC, 1.5A US/Euro/UK/Australian style plug available.
Dimension	243.5mm x 168mm x 36mm.
Weight	1.04kg (phone with handset and stand), 1.95kg (package weight).
Operating Temperature	32° F - 104° F/0° C - 40° C.
Humidity	10%-90% Non-Condensing.
Compliance	FCC/CE/C-Tick.

Table 3: GXV3175 Technical Specifications

Lines	Three individual SIP accounts.
Protocol Support	SIP 2.0, UDP/IP, PPPoE, RTP/RTCP, SRTP by SDES, HTTP, ARP/RARP, ICMP, DNS, DHCP, NTP/SNTP, TFTP.
Display	7" resistive touch screen LCD with 800 x 480 resolution.
Network Interfaces	Dual switched 10M/100M auto-sensing Ethernet ports, 2 x USB 2.0 port, 1 x audio/video output port (to synchronize output video to TV), stereo headset jack.
Device Management	Layer 2 QoS (IEEE 802.1p/Q tagging-VLAN) and Layer 3 QoS (ToS, DiffServ, MPLS), web interface or via secure (AES encrypted) central configuration file for mass deployment, auto/manual provisioning system, remote software (TFTP/HTTP/HTTPS) upgrade for deployed devices including those behind NAT/firewall.
Provisioning	<ul style="list-style-type: none"> - Support for automatic NAT/firewall traversal and remote automatic software upgrade and security, providing end-users with "zero configuration" and true "plug-and-play" functionality. - Support for remote configuration monitoring and syslog. - Configuration through LCD, web browser or an external configuration file. - Support for IETF STUN NAT traversal and symmetric RTP, Static IP or DHCP.
Audio Features	<ul style="list-style-type: none"> - HD handset and full duplex speaker, advanced DSP. - Supports G.723.1, G.729A/B, G.711μ/A (PCMU/PCMA), G.726-32, G.722, GSM-FR, L15-256 DTMF (In-audio, RFC2833, SIP Info); Silence suppression, VAD, CNG, AGC, masking for packet loss/delay; AEC, AGC for Speaker; jitter buffer protocol.
Video Features	<ul style="list-style-type: none"> - Support for Jitter Buffer delay and packet loss concealment to enhance audio and video quality. - Support for H.263/H.263+ and H.264 real-time video codecs (CIF or QVG) up to 30frames/sec, which ensures high quality video transmission even under low bandwidth conditions (32kbps-1Mbps). - 7" resistive touch screen LCD with 800 x 480 resolution, 45 degree rotating lens (perpendicular), advanced VGA CMOS camera and sensor. - Anti-flickering of images, auto focus, auto exposure, zoom (2x optical 2x digital), PIP(Picture-in-Picture), audio mute, camera block, call log, video phone book, screensaver, still picture capture/store (VGA) and visual voice message indicator.
Call Handling Features	Caller ID, call waiting ID, call waiting/flash, call transfer, call holding, call forwarding, Do-Not-Disturb, three-way conference, redial, automatic dialing on off-hook, automatic answering, call records, volume control, voice message waiting indicator, downloadable custom ring tone, switchable handset/headset/speaker during call.

Caller ID (Privacy)	Private header support for anonymous calls.
Firmware Upgrade	<ul style="list-style-type: none">- Configuration file authentication (before accepting changes).- TFTP/HTTP upgrade support, allows users to specify different URLs for the server to download from.
Advanced Server Features	DNS SRV support, SIP server failure transfer, message waiting indicator and custom screensaver.
Security	<ul style="list-style-type: none">- MD5 and MD5-sess DIGEST encoding and authentication.- Security protection: SIP over TLS and SRTP.- Support for TR-069.- Support for OpenVPN for increased security and control.

INSTALLATION

EQUIPMENT PACKAGING

This GXV3175 package contains:

1. One (1) GXV3175 Phone Main Case with One (1) Stylus inserted in the back
2. One (1) Handset
3. One (1) Quick Start Guide
4. One (1) Headset Dongle
5. One (1) Ethernet Cable
6. One (1) Phone Cord
7. One (1) 12V Power Adapter
8. One (1) Phone Stand
9. One (1) Wall Mount
10. One (1) TV VGA Adapter Cable

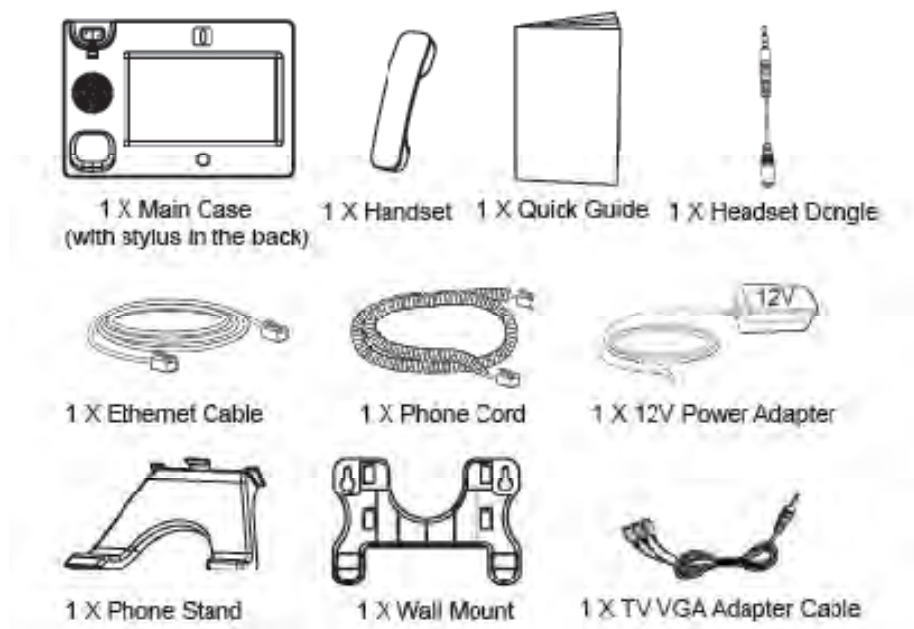


Figure 1: GXV3175 Equipment Packaging

SAFETY COMPLIANCES

GXV3175 complies with FCC/CE/C-Tick safety standards. The power adapter of GXV3175 is compliant with the UL standard. Please use the universal power adapter provided with the GXV3175 package only.

The manufacturer's warranty does not cover damages to the phone caused by unsupported power adapters.

WARRANTY

If GXV3175 was purchased from a reseller, please contact the company the phone was purchased for replacement, repair or refund. If the phone was purchased directly from Grandstream, please contact Grandstream Sales and Service Representative for a RMA (Return Materials Authorization) number before the product is returned. Grandstream reserves the right to remedy warranty policy without prior notification.

WARNING: Use the power adapter provided with the phone. Do not use a different power adapter as this may damage the phone. This type of damage is not covered under warranty.

CONNECTING THE GXV3175 IP MULTIMEDIA PHONE

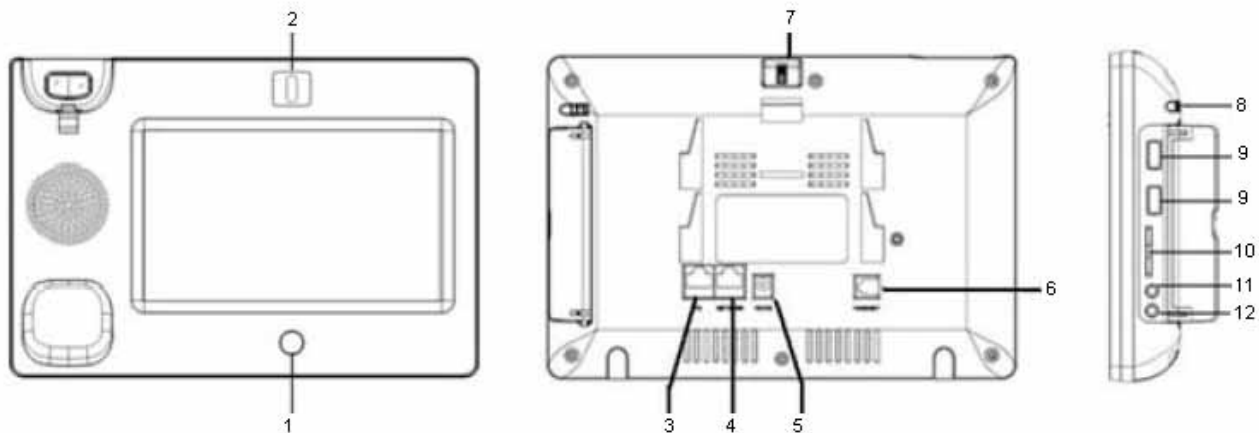


Figure 2: GXV3175 Ports and Interface

Table 4: GXV3175 Ports and Interface

Item	Name	Description
1	Home Button	Press Home button to navigate to main screen
2	Camera	1.3M pixel adjustable CMOS camera with privacy shutter
3	PC Ethernet Port	10/100Mbps RJ-45 port connecting to PC
4	Network Ethernet Port	10/100Mbps RJ-45 port connecting to Ethernet
5	Power Jack	12V DC Power connector port
6	RJ11 Jack	Phone handset connector port
7	Camera Adjust Wheel	Scroll the wheel to turn on/off the camera;

		Adjust the camera position and lens angle
8	Stylus	Stylus for touch screen (optional)
9	USB Port	USB devices may be connected via the USB port. For example, you can connect a USB flash drive to save captured pictures and plug in USB keyboard or mouse for the built-in web browser
10	SD Card Slot	SD card could be inserted in for picture/music/video files storage
11	Headset Jack	3.5mm stereo headset connector port
12	RCA Video/Audio Jacks	Audio/video output port for external peripherals (e.g. TV)

WALL MOUNT

GXV3175 has two slots on the back of the phone for wall mounting convenience. (See Figure 3)

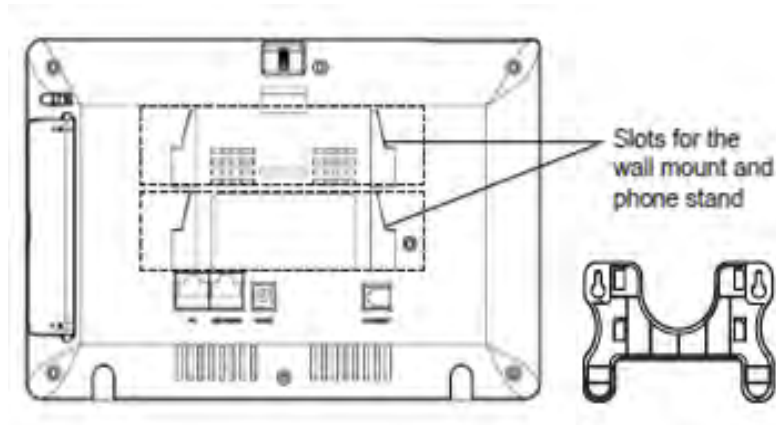


Figure 3: Wall Mount for GXV3175

PHONE STAND

GXV3175 can also be placed on the table or desk via the phone stand. (See Figure 4) There are two positions for the stand on the back of the phone with each position supporting a different angle.

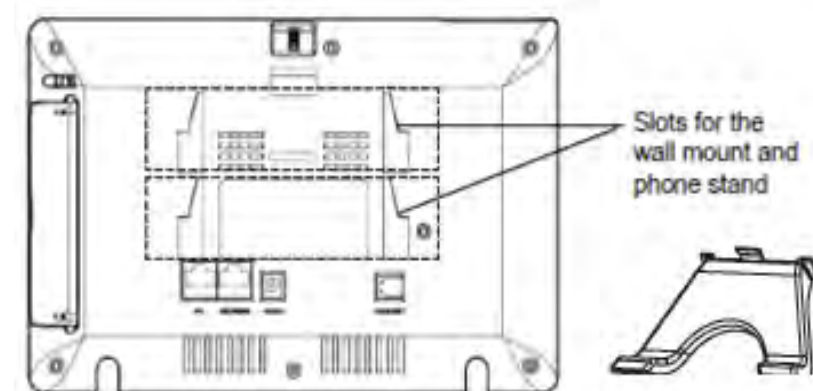


Figure 4: Phone Stand for GXV3175

CONNECTING GXV3175 IP MULTIMEDIA PHONE

CONNECTING THE PHONE:

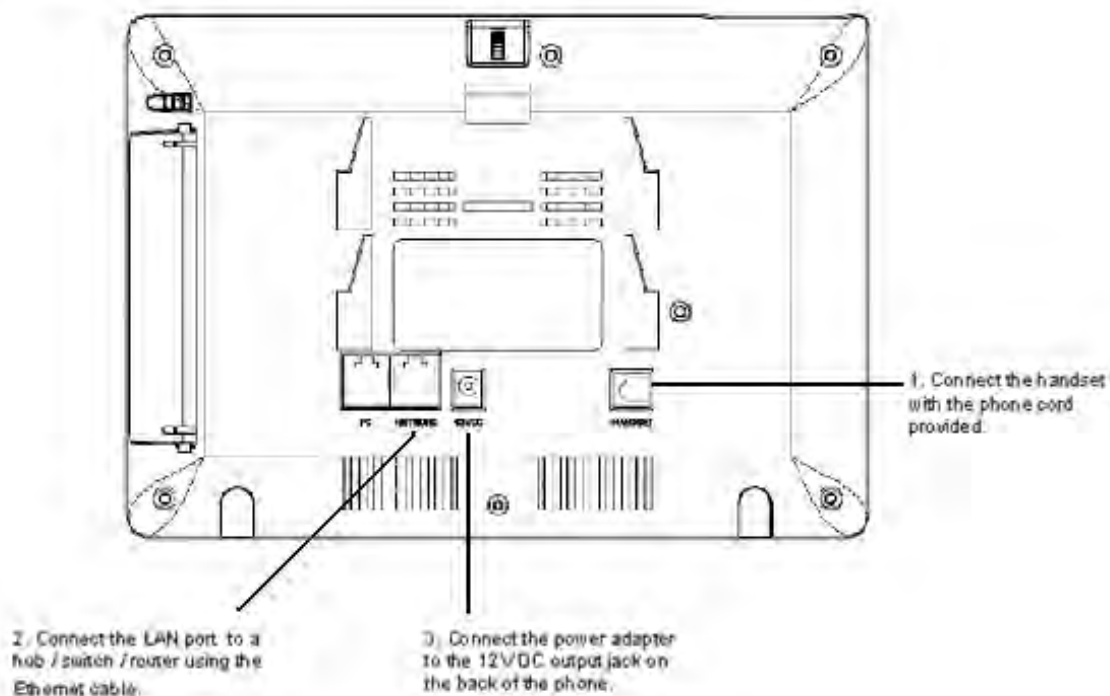


Figure 5: Connecting the GXV3175

MAKING THE FIRST CALL WITH IPVIDEOTALK SERVICE

GXV3175 offers users the ability to send and receive free lifetime video calls to other GXV3175/GXV3140 on the IPVideoTalk network. Once the GXV3175 is connected, video calls can be made using Grandstream's configuration peer-to-peer SIP technology and IPVideoTalk service. To place the first video call, complete the following three simple steps:

- 1) Connect the handset, network cable and power adapter to the GXV3175 using the methods described above. After the phone boots up and obtains an IP address through DHCP, it will attempt to register to the IPVideoTalk network. When the user boots the phone for the first time, Account 1 will be registered to the IPVideoTalk server with a provisioned extension number 810xxxx.
- 2) If the registration is successful, the "IPVideoTalk" text on the LCD will turn green and an assigned IPVideoTalk number (810xxxx) specific to this phone will be displayed. At this point, the phone is ready for making and receiving video calls over the IPVideoTalk network.

- 3) Tap on the account (See Figure 5) in the touch screen then the dial pad will show up for on-hook dialing (See Figure 6). Dial the number of any other phone registered on the IPVideoTalk network and press “Video Call” or “Audio Call” button in the dial pad. If the user has purchased more GXV3175/GXV3140 IP Multimedia phones, these phones are able to establish video calls between each other and the user will immediately experience the plug and play nature of the GXV3175. If a user has only one GXV3175, the user can choose to experience the multimedia features by dialing 0 to establish a video call with the preset extension on the server.



Figure 6: Select IPVideoTalk account in the marked area to make first call



Figure 7: Press 0 and select Video Call



Figure 8: Establishing Video Call in GXV3175

USING THE GXV3175 IP MULTIMEDIA PHONE

LCD

When the phone is idle, the LCD screen will look similar to Figure 9. (The account and IP address may be different from case to case, depending on the network environment and the settings.)



Figure 9: GXV3175 LCD Idle Screen

Users could hold and drag on the center area of the main screen then slide from right to left to switch the screen to view the different desktop widgets in the four screens. In the left hand side of the status bar, there are four green tabs indicating the current page of the screen.

Figure 10 shows the screen that displays weather and currency information.



Figure 10: LCD IDLE screen displaying Weather and Currency Information

Move around all the way to left to switch to screen that displays News Videos and Stock information. See Figure 11.



Figure 11: LCD Idle screen displaying News Videos and Stock information

Switch again to the last screen that shows Calendar and RSS News. See Figure 12.



Figure 12: LCD Idle screen displaying Calendar and RSS News


In Figure 12, on the button menu of each screen, users could select “Menu” to access the full menu, select “Phone” to make a call, select PIP, News Videos, Youtube, Internet Radio or Browser for the corresponding applications. If the users press  button on the left, new widgets which include Info, Weather, RSS News, Contacts and Internet Radio will be available to open and display in the main screen. (See Figure 13)



Figure 13: Open new widget in Idle screen

Users may close/configure the widget by holding the finger on the widget area until close/setting options show up on the right (Marked in Figure 14).






Figure 14: Close/Configure the widget in Idle screen


On the top of the screen, tap on the status bar on the right, users will be able to see more status in the popped out dropdown list. See Figure 15.



Figure 15: LCD Idle screen displaying status bar settings

Table 5: LCD Icon Definition

Type	Icon	Definition	Note
Network		Connected to the network	
		Failed to connect to the network	
Call Related		Account 1 Auto Answer	



		Account 2 Auto Answer	
		Account 3 Auto Answer	
		Account 1 Call Forward	If call forward is on: unconditional forward, forward when busy or forward on no answer.
		Account 2 Call Forward	
		Account 3 Call Forward	
Ring Volume		Ring volume, ranges from 0-9	
Phone Status		Camera disabled.	
		Do-Not-Disturb (DND)	
		Missed Call	
Audio Output		The headset is in use and is off hook.	
		The headset is plugged in	
		The phone is on speaker	
		The handset is off hook	
WiFi		WiFi signal strength, ranging from 0 to 4	
			
			
			
			
Message		Unread message	The icon is displayed at the right hand side of the status bar
		Message box is full	
Applications		Unread text message	
		Alarm clock	
		Background running program	The icon is displayed at the center of the status bar
External devices		SD card	
		USB flash drive	
		USB keyboard	
		USB mouse	

MULTIPLE SIP ACCOUNTS AND LINES



Figure 16: GXV3175 Dial Pad

Table 6: GXV3175 Dial Pad Definition

Item	Definition
1	Line/Account selection. Three independent SIP accounts may be configured, and the Line options can be used to choose the line/account for audio/video call.
2	Account option. Dropdown list will show all the registered account for selection.
3	Call option. Dropdown list will show three types of call: Call, Paging and IP Call for direct IP Cal.
4	Audio output. Three types of audio output are available: speaker, handset and headset.
5	Call volume. Press  to turn down or press  to turn up the volume.
6	Standard keypad.
7	Delete input number. Press to delete the input number when dialing out.
8	Contacts. Press to open contact list.
9	Call History. Press to open call history.
10	Message. Press to open message box.
11	Voice Mail. Press to access voice mail box.

The GXV3175 supports up to 3 independent SIP accounts. Each account may have separate SIP servers,

usernames and NAT configurations. The registered account will display in the idle screen by default. When the phone is off-hook, users could press Line1/Line 2/Line 3 or the account option in the dial pad shown in Figure 16 to switch between different SIP accounts.

Incoming calls through the three accounts will try to use the corresponding line. If this line is busy, the green icon for the corresponding line will become red. When a call comes in and the line is busy, the next idle line will be used.

HANDSET, SPEAKER AND HEADSET MODE

The GXV3175 allows users to switch from handset to speaker or headset by pressing corresponding icons shown in Dial Pad (Table 6, Item 5). If headset is plugged in, the headset icon will be activated to select.

MAKING A CALL

There are several ways to make a call.

1. By selecting account displayed in idle screen


Users could press the account area displayed in idle screen to make a call via the selected account.

- In idle screen, select the registered account by touching the marked area in Figure 17.
- The dial pad will show up with the selected account.
- Dial the number and press “Audio Call” or “Video Call” to dial out. Or press “Redial” for the last dialed number.



Figure 17: Making a call by select account displayed in idle screen

2. By “Phone” in idle screen


- In idle screen, select the “Phone” icon  in the bottom menu.
- The dial pad will show up with dial tone.
- Dial the number and press “Audio Call” or “Video Call” to dial out. Or press “Redial” for the last dialed number.

3. By taking handset off hook

Users will be able to make a call when the phone is idle or running other applications by taking the handset off hook.

- Take the handset off hook then the dial pad will show up with dial tone.
- Select line/account.
- Press “Redial” or dial the number and press “Audio Call”/“Video Call” to dial out.

4. By Call History

- Access the Phone Menu by pressing “MENU” icon in idle screen, and then select “Call history”.
- The LCD monitor will display “All” calls, “Received” calls, “Dialed” calls and “Missed calls”. Select the call history that you wish to view.
- Press  to dial the selected number. (See Figure 18)

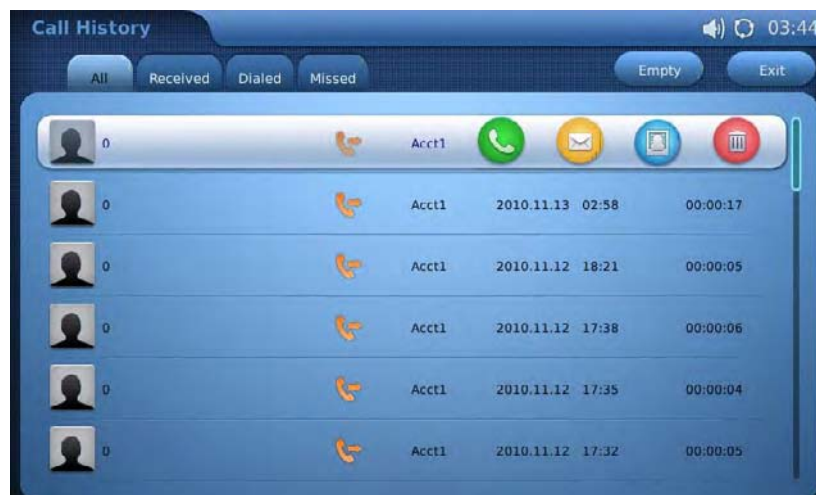



Figure 18: Dial by Call History

5. By Contacts

- Access the Phone Menu by pressing “MENU” icon in idle screen, and then select “Contacts”. Or choose “Contacts” icon in dial pad to access contact list.
- The LCD monitor will display the contact list. Scroll to the contact to be dialed.
- Press  to call the select contact. The primary number of the contact will be dialed out.

See Figure 19.

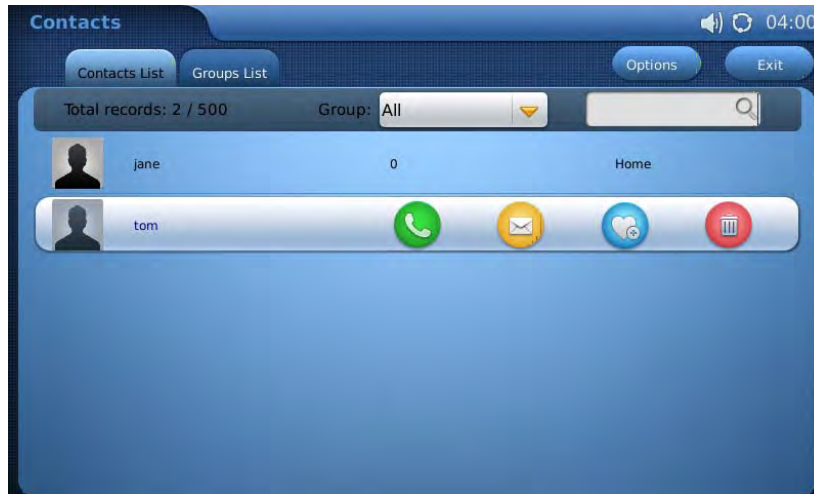


Figure 19: Dial by Contact List

- If selecting the contact for full contact information, there will be four numbers available to dial out: Home, Work, Mobile and Fax. Press  to dial the corresponding number. See

Figure 20.



Figure 20: Dial by Contact List – more contact information

6. By Contact Favorite in idle screen





In idle screen, press  and select  to open the “Contacts” widget. Users could add the contact to the favorite list. Select the contact and press  to dial out. (See Figure 21)



Figure 21: Dial by Contact Favorite in idle screen

7. By Messages

Users could access the Phone Menu by pressing “MENU” icon in idle screen, and then select “Message”. Similar to dialing by Call History, press  to dial the selected contact in message history.

DURING CALLS

ANSWERING CALLS

- 1. Incoming Video Call:** When the phone rings, select “Accept Audio”, “Accept Video” or “Reject”. (See Figure 22) Users could toggle among handset/speaker/headset to answer the call and adjust the call volume by pressing the speaker icon as well.



Figure 22: Answer incoming video call

2. **Incoming Audio Call:** When an audio call is coming in, select “Accept Audio” or “Reject” in the screen shown as Figure 23.



Figure 23: Answer incoming video call

3. **Missed Call:** if the call is unanswered, a missed call message will show up in idle screen. (See Figure 24). Users could press View to access the detail of the missed call.



Figure 24: Answer incoming video call

CALL FUNCTION OPTIONS

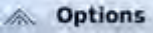
Figure 25 shows the screen after the users answer the call. Press “Options” button  to access all the call functions.



Figure 25: Use Call Options during a video call

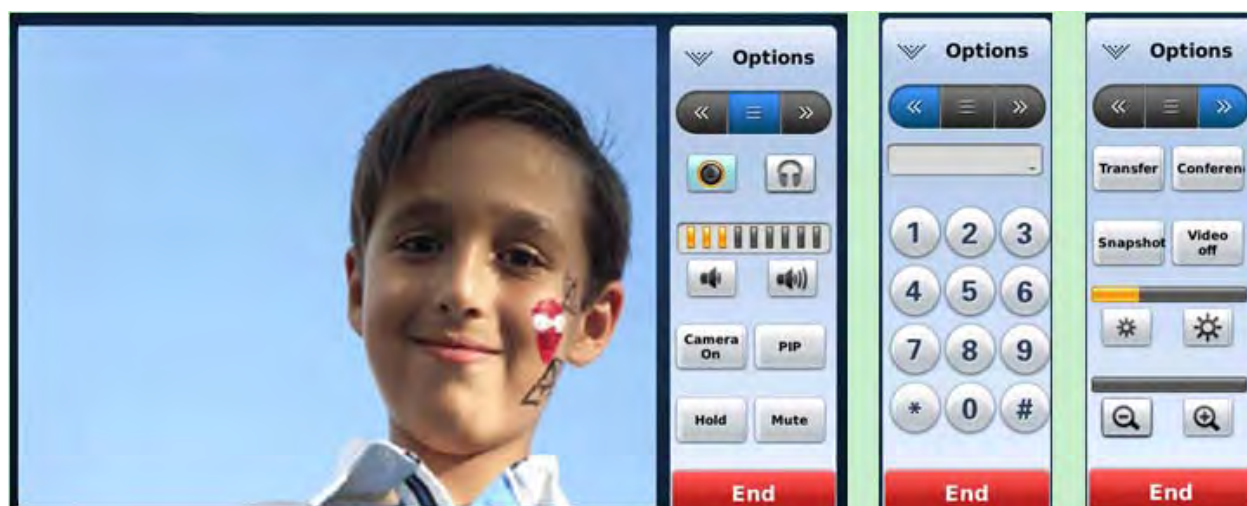
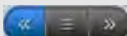






Figure 26: Call Function Options

Table 7: GXV3175 Call Function Description

OPTION MENU	FUNCTION	DESCRIPTION
	Camera On	Press to switch between Camera On and Camera Off
	PIP	Press to switch videos between the caller and callee
	Hold	Press to hold the call
	Mute	Press to mute/unmute the call
	Transfer	Press to make transfer to the third party
	Conference	Press to make 3-way conference call
	Snapshot	Press to take a snapshot of the current video. The snapshot will be automatically saved to folder "screenshot" in Tools->File Manager
	Video off	Press to switch between Video off and Video on. In the screen, the default picture will show instead of the video when video is turned off
		Turn up and turn down the video brightness
		Video zoom in and turn out
	DTMF Dial Pad	Press the number and # or * for DTMF

CALL HOLD

- 1. Call Hold:** During a call, press "Hold" button to place the call on hold. The line icon will become yellow after call hold. The following will be displayed on the screen. (See Figure 27)



Figure 27: Call Hold

2. **Call Resume** In Figure 27, press “Unhold” button to resume to the call.
3. **Multiple Calls:** After call hold, users could select another line to make calls. If there is another call coming in, the user will be able to select “Accept” or “Reject” in the right hand side of the screen. Accept new incoming call will put the previous call on hold. To toggling between several calls, users may need to turn off the video first by tapping on “Video off” in “Option” (See Figure 24) if it is a video call. Then the following figure will show up for users to select between multiple lines. See Figure 28.



Figure 28: Multiple Calls

CALL TRANSFER

1. **Blind Transfer:** During a call, press the “Transfer” button to place the other party on hold. The phone will display the following message: “Dial Number (Blind) OR Select Line (Attended)”. (See

Figure 29). Dial the extension number and press “Send”. This will transfer the call to the other party immediately.

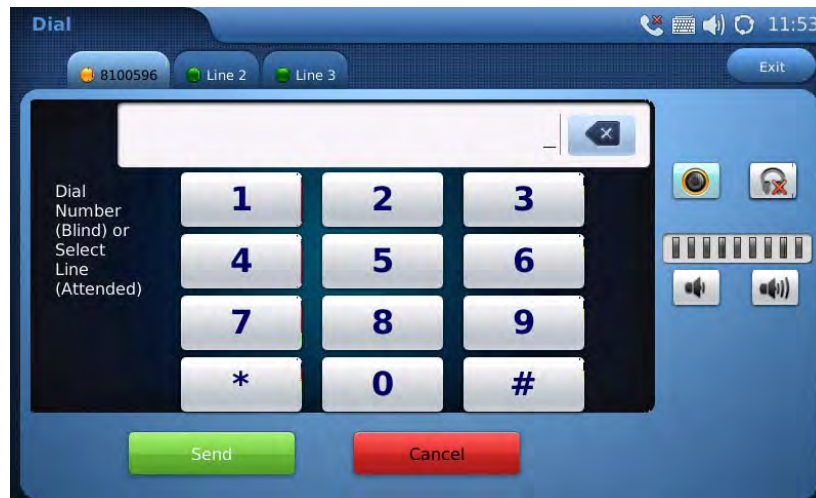


Figure 29: Blind Transfer

- 2. Attended Transfer:** During a call, select another line to establish call with the third party using the same account. This will put the previous line (Line 1) on hold. Now, press the “Transfer” button and the message: “Dial Number (Blind) OR Select Line (Attended)” will show up in the screen. Then select Line 1 to finish attended transfer. (See Figure 30)

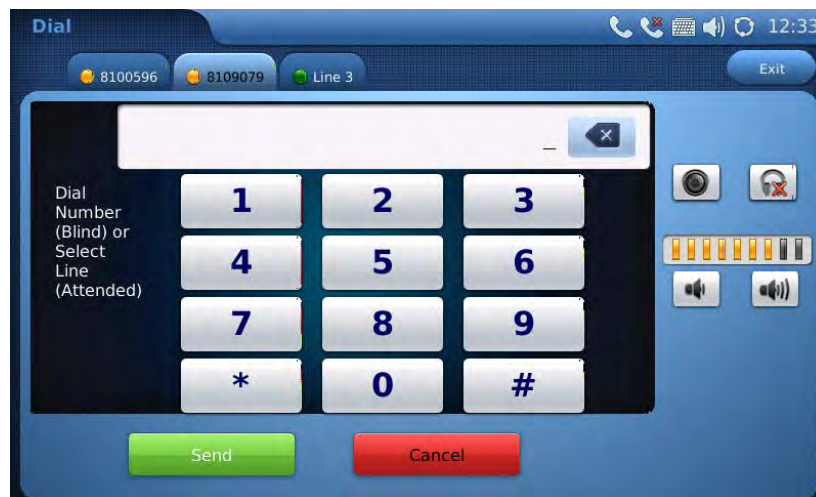


Figure 30: Attended Transfer

NOTE:

- To transfer calls across SIP domains, SIP service providers must support transfer across SIP domains.

- If users enter a wrong number and wish to cancel the transfer, just press the “Cancel” in the screen shown in Figure 27. Then the call with the first party will resume automatically.
- If the user is on a video call with the first party, the users may need to turn off the video by pressing “Video off” or pressing “Hold” to activate the screen to select another line.

3-WAY CONFERENCE

The GXV-3175 supports 3-way video conferencing. See Figure 31.



Figure 31: 3-Way Conference

- 1. Initiate a Conference Call:** During a call, select another line by pressing “Line” button to call the second party using the same account. This will place the first call on hold. Once the user has established the second call, press the “Conference” button then select the line on hold by pressing the corresponding “Line” button. This would bring the three parties together in a 3 way conference.
- 2. Cancel the Conference:** If after pressing the “Conference” button, a user decides not to conference anyone, press “Cancel” to cancel the conference.
- 3. End the Conference:** There are two ways to end a conference: The first way is to press “END” in the conference call. The second way to end a conference is to simply hang up and terminate the call.



NOTE:

- During the conference, users can see three-way videos if it is video call.
- To activate the call options during the conference, users could simply tap on the screen then the options will show up. Press PIP button to change the layout of the video display for the three parties.
- During the three way conference, if the initiator of the conference hangs up, the conference will end. If users wish to allow the remaining two parties to stay in conversation after the initiator hangs

up, the conference initiator should set “Transfer on Conference Hangup” to “Yes” in the web configuration interface. This would allow the transfer of call to the remaining party after the initiator exits the conference.

- If the user is on a video call with the first party, the users may need to turn off the video by pressing “Video off” or pressing “Hold” to activate the screen to select another line.

VOICEMAIL (MESSAGE WAITING INDICATION)

If the blue Message Waiting Indication (MWI) LED icon is flickering in the HOME button, a new voice mail has been received and is waiting to be retrieved. To retrieve the voice mail, activate dial pad first. Then dial the voicemail box number or press Voice Mail button  (the button needs to be configured in web configuration interface first). The Interactive Voice Response (IVR) prompts the user through the message retrieval process. The users may need to navigate to call function option  and use the DTMF keypad for voicemail options.

NOTE: Each of the 3 accounts has its own voicemail. The Voicemail access number may be set up in the “Voicemail ID” configuration under “Accounts” in the web configuration interface.

MUTE

1. During a call, the LCD screen will display “Mute”. Select the button to mute the call.
2. After the “Mute” button is pressed, the LCD screen will display “Unmute”. When this button is pressed, the mute feature is cancelled.

KEYPAD INPUT

The build-in soft keypad in GXV3175 supports English and Chinese for text input. See Figure 32.



Figure 32: GXV3175 Soft Keypad

Table 8: GXV3175 Keypad Definition

Item	Function
1	Caps lock.
2	Hide keypad
3	Switch between English/Chinese input.
4	Switch between Letter/Number/Symbol
5	Delete

NOTE: External keyboard could also be used by plugging via USB port on the phone.

CALL FEATURES

The following table shows the codes for call features. To use the code, select the line you wish to use by pressing the corresponding Line button and enter the feature code.

Table 9: GXV3175 Call Features

Code	Feature
*01	Select the preferred video/audio codec used for the call. Dial *01 + codec feature code + Phone/Ext. Number (See Table 8 for codec feature code)
*02	Force the video/audio codec used for the call. Dial *02 + codec feature code + Phone/Ext. Number (See Table 8 for codec feature code)
*30	Block Caller ID (for all subsequent calls)
*31	Send Caller ID (for all subsequent calls)
*50	Disable Call waiting (for all subsequent calls)
*51	Enable Call Waiting (for all subsequent calls)
*67	Block Caller ID (per call): Dial *67 + Phone/Ext. Number (no dial-tone in between).
*82	Send Caller ID (per call): Dial *82 + Phone/Ext. Number (no dial-tone in between).
*83	Send audio only: Dial *83 + Phone/Ext. Number (no dial-tone in between)
*84	Send audio and video: Dial *84 + Phone/Ext. Number (no dial-tone in between)
*70	Disable Call Waiting (per call): Dial *70 + Phone/Ext. Number (no dial-tone in between).
*71	Enable Call Waiting (per call): Dial *71 + Phone/Ext. Number (no dial-tone in between).
*72	Unconditional Call Forward: Dial *72 + Phone/Ext. Number followed by the # key. Wait for a dial-tone and then hang up (dial-tone means input is successful).
*73	Cancel Unconditional Call Forward: Dial *73 and wait for a dial-tone before hanging up.
*90	Busy Call Forward: Dial *90 + Phone/Ext. Number followed by the # key. Wait for a dial-tone and then hang up.
*91	Cancel Busy Call Forward: dial *91 and wait for a dial-tone before hanging up.
*92	Delayed Call Forward: Dial *92 + Phone/Ext. Number followed by the # key. Wait for a dial-tone and then hang up.
*93	Cancel Delayed Call Forward: Dial *93 and wait for a dial-tone before hanging up.

Table 10: GXV3175 Audio/Video Codec Feature Code

Codec	Feature Code
PCMU	7110
PCMA	7111

G723	723
G726-32	72632
G729	729
G722	722
GSM	7200
L16-256	7202
H.264	264
H.263	263
H.263+	2631998

GXV3175 WEB CONFIGURATION INTERFACE

The GXV-3175's embedded Web server responds to HTTP/HTTPS GET/POST requests. Embedded HTML pages allows users to configure the IP Multimedia Phone through a Web browser such as Microsoft's IE or Mozilla Firefox (Java Script must be enabled).

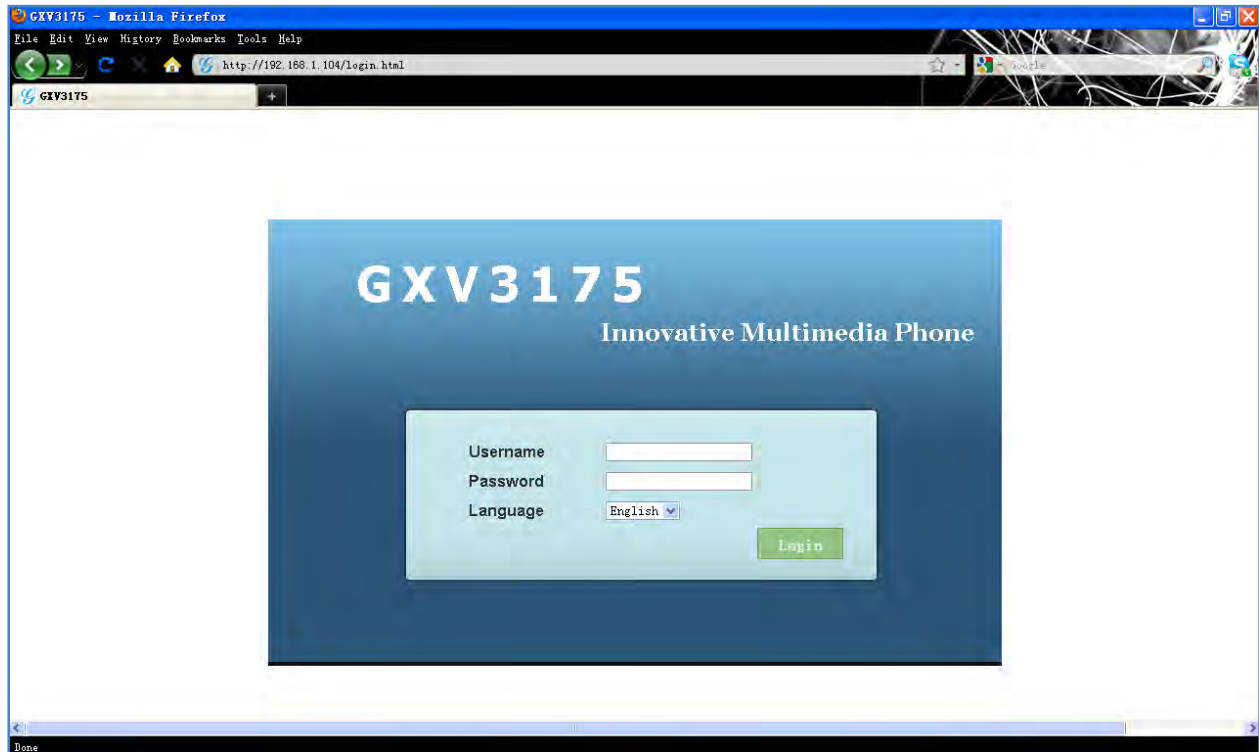


Figure 33: Web Browser Interface for GXV3175

ACCESSING THE WEB CONFIGURATION PAGES

The GXV3175 Web Configuration Interface URL is *http://Phone-IP-Address*, where the *Phone-IP Address* is the IP address displayed on the phone's LCD screen.

To access the phone's Web Configuration Menu:

- Connect the computer to the same network as the phone.
- Make sure the phone is turned on and shows its IP-address on the LCD display.
- Open a Web-browser on your computer.
- Enter the phone's IP-address in the address bar of the browser.
- Enter the administrator's login and password to access the Web Configuration Menu.

1. The computer has to be connected to the same sub-network as the phone. This is easily done by connecting the computer to the same hub or switch as the phone it is connected to. In absence of a hub/switch (or free ports on the hub/switch), please connect the computer directly to the phone using the PC-port on the phone.
2. If the phone is properly connected to a working Internet connection, the phone will display its IP address. This address has the format: xxx.xxx.xxx.xxx, where xxx stands for a number from 0-255. Users will need this number to access the Web Configuration Menu. For example, if the phone shows 192.168.0.60, please enter “*http://192.168.0.60*” in the address bar of the browser.
3. The default login name for the administrator is “admin”. The default administrator password is set to “admin”. The default login name for end-users is “user” while the default user password is set to “123”.

NOTE: When changing any settings, always SUBMIT them by pressing the SAVE button on the bottom of the page. For those settings that are shown in the web user interface (UI) with a star “*” next to it, users must reboot the phone for the changes to take effect.

DEFINITIONS

This section describes the options in the Web configuration user interface. As mentioned, you can log in as an administrator or an end-user.

- **Status:** Displays the Account status, Network status, and System info of the phone.
- **Account (1~3):** To configure each of the SIP accounts.
- **Advanced Settings:** To configure General settings, Call Features, Video Settings, and Ring Tones.
- **Maintenance:** To configure Network Settings, WiFi Settings, Time Settings, Web/Telnet Access, Upgrade, Syslog, Debug, Language, Network Manager, OpenVPN Settings and Device Manager.

STATUS PAGE DEFINITIONS

Status/Account Status

Account	Shows the status of the 3 accounts.
Number	Shows the extension number of the SIP account.
SIP Server	Shows the URL/IP address and port of the SIP server.
Status	Shows the status of the account.

Status/Network Status

MAC Address	The device ID, in HEX format. This is a very important ID for ISP troubleshooting.
Address Type	This field shows the type of address configured: DHCP, Static IP or PPPoE.
IP Address	This field shows the IP address of the GXV-3175.
Subnet Mask	This field shows the subnet mask of the GXV-3175.
Default Gateway	This field shows the Gateway of the GXV-3175.
DNS Server	This field shows the DNS Server of the GXV-3175.
NAT Type	This field shows the type of NAT configured.

Status/System Info

Product Model	Defines the product model: GXV3175.
Hardware Revision	Hardware version number: Main Board, Interface Board.
Part Number	This field contains the product part number.
Serial Number	This field contains the product serial number.
Software Version	<ul style="list-style-type: none"> • Program: This is the main firmware release number, which is always used for identifying the software (or firmware) system of the phone. • Boot: Booting code version number. • Core: Core code version number. • DSP: DSP code version number. • Base: Base code version number. • GUI-A, GUI-B: GUI interface version number. • Recover Image: Recover image version number. • Supplement: Supplement version number.
System Up Time	This field shows system up time since the last reboot.

ADVANCED SETTINGS PAGE DEFINITIONS

Advanced Settings/General Settings

Local RTP Port	This parameter defines the local RTP-RTCP port pair used to listen and transmit. It is the base RTP port for channel 0. When configured, for audio, channel 0 will use this port _value for RTP and the port_value+1 for its RTCP; channel 1 will use port_value+4 for RTP and port_value+5 for its
----------------	---

	RTCP. For video, channel 0 will use port_value+2 for RTP and port_value+3 for its RTCP; channel 1 will use port_value+6 for RTP and port_value+7 for RTCP. The default value is 5004.
Use Random Port	When set to YES, this parameter will force random generation of both the local SIP and RTP ports. This is usually necessary when multiple GXV-3175s are behind the same full cone NAT. The Default setting is YES. (This parameter must be set to NO before Direct IP Calling will work)
Keep-alive Intervals (s)	This parameter specifies how often the GXV-3175 sends a blank UDP packet to the SIP server in order to keep the “ping hole” on the NAT router to open. The default setting is 20 seconds.
STUN Server	The IP address or Domain name of the STUN server. STUN resolution results are displayed in the STATUS page of the Web UI. Only non-symmetric NAT routers work with STUN. Default STUN server: stun.ipvideotalk.com
Use NAT IP	The NAT IP address used in SIP/SDP messages. This field is blank at the default settings. This should ONLY be used if your ITSP requires it.
SSL Certificate	This defines the SSL certificate needed to access certain websites.
SSL Private Key	This defines the SSL Private key.
SSL Private key Password	This defines the SSL private key password.

Advanced Settings/Call Features

Disable Call-Waiting	The default setting is No. If set to Yes, the call waiting feature will be disabled.
Disable Call-Waiting Tone	The default setting is No. If set to Yes, the call waiting tone will be disabled.
Disable Direct IP Call	The default setting is No. If set to Yes, Direct IP calling will be disabled.
Offhook Auto Dial	Configure a User ID/extension to dial automatically when the phone is taken offhook. By default, the phone will use the first account to dial out.

Advanced Settings/Video Settings

Enable Motion Detection	The phone will exit idle/screensaver mode if motion is detected. The default setting is Yes.
Video Frame rate	The Default value is 15 frames/second. The video frame rate is adjustable based on network conditions. Increasing the frame rate will increase the amount of transferred data significantly therefore consuming more bandwidth. Lack of bandwidth will

	impair the video due to packet loss.
Video Packet Size	The Default value is 1400, range from 100 to 1400. It is recommended to use 600~800 if you have an Outbound Proxy or Media Gateway.
Video Rate Control	Frame, TMN8 or GOP. The Default setting is Frame. TMN8 is good for bandwidths larger than 384kbps
Video Frame Skipping	Skips bad video frames as they are received The Default setting is No.
I-Frame Reference Only	When enabled, all P frames will only have reference to previous I frames. This method may improve video quality when the network has heavy packet loss. It will have modest increase in bandwidth usage. The Default setting is No.
Packetization-Mode	The packetization mode (0 or 1) for the H.264 video packets. The default setting is 0.
Redundant P-frame	This setting allows the phone to send redundant P-frames of I frames. When an I frame is delayed or has packet loss, the redundant P-frames will be used instead. It may make video phone call less prone to errors and thus make the video stream more robust towards error propagation, but may increase bandwidth usage. The default setting is set to No.
Adaptive MB Intra Refresh	This parameter specifies whether Adaptive MB Intra Refresh is used or not. It may protect most important MBs (macro blocks) subjected to packet loss and to avoid error propagation. The intra-refresh rate is adapted according to the video packet loss rate. It may increase bandwidth usage. The default setting is set to No.
Video Packet Loss Rate	Specifies the video packet loss rate for the Adaptive MB Intra Refresh. Users can choose from: Less than 5%, Less than 10%, Less than 15%, Less than 20%, Less than 25%. The default setting is set to Less than 10%.

Advanced Settings/Ring Tone

Call Progress Tones: Dial Tone Ring Back Tone Busy Tone Reorder Tone Confirmation Tone Call-Waiting Tone	Using these settings, users can configure ring or tone frequencies based on parameters from the local telecom provider. By default, they are set to the North American standard. Frequencies should be configured with known values to avoid uncomfortable high pitch sounds. Syntax: f1=val,f2=val[,c=on1/off1[-on2/off2[-on3/off3]]]; (Frequencies are in Hz and cadence on and off are in 10ms)
--	--

PSTN disconnect Tone	ON is the period of ringing (“On time” in ‘ms’) while OFF is the period of silence. In order to set a continuous ring, OFF should be zero. Otherwise it will ring ON ms and a pause of OFF ms and then repeat the pattern. Up to three cadences are supported.
Default Ring Cadence	This defines the ring cadence for the phone. The default setting is: c=2000/4000;

MAINTENANCE PAGE DEFINITIONS

Maintenance/Network Settings

Address Type	This selects the type of IP address assigned: DHCP, PPPoE or Static IP.
PPPoE	When PPPoE is selected, the user needs to enter the following: PPPoE Account ID, PPPoE Password, PPPoE Service Name.
Static IP	When Static IP is selected, the user needs to enter IP address, Subnet Mask, Default Gateway, DNS Server 1 and DNS Server 2.
Alternate DNS Server	This field sets the alternate DNS server for the user.
Layer 3 QoS	This field defines the layer 3 QoS parameter. It is the value used for IP Precedence, Diff-Serv or MPLS. The Default value is 0.
Layer 2 QoS 802.1Q/VLAN Tag	This field contains the value used for layer 2 VLAN tagging. The Default value is 0.
Layer 2 QoS 802.1p Priority Value	This assigns the priority value of the Layer2 QoS packets. The Default value is 0.
802.1x Mode	This field sets 802.1x Mode. The default value is disabled. If EAD-MD5 is selected, users will be required to enter Identity and MD5 Password.
Proxy	This field sets HTTP Proxy, HTTPS Proxy, FTP Proxy or No Proxy. Using HTTP Proxy, other protocols can be applied by checking the box “Apply to Other Protocol”.

Maintenance/Wifi Settings

WiFi Functions	This parameter enables/disables the WiFi function. The default setting is set to “Disable”.
Wireless Mode	This parameter defines the wireless mode used. The GXV3175 supports 802.11b/g/n
Network Type	This parameter defines the network type of the wireless network: Ad-hoc or

	AP/Managed. By default, it is set to “AP or Managed”.
Channel	This parameter defines the channel (1-10) for the wireless network. The default setting is set to “Auto”.
ESSID	This parameter sets the ESSID for the Wireless network. Press “Scan” to scan for the available wireless network and add it. Users can also press “Add” to add the ESSID directly.
Security Mode	This parameter defines the security mode used for the wireless network. The following are supported: WEP/Shared, WEP/OPEN, WPA PSK TKIP, WPA PSK AES, WPA2 PSK TKIP, WPA2 PSK AES. The default setting is set to “Disabled”. Users will need to enter the corresponding authentication password for the security mode.

Maintenance/Time Settings

NTP Server	This parameter defines the URL or IP address of the NTP (Network Time Protocol) server. The GXV3175 phone may obtain the date and time from the server. The default setting is ntp.ipvideotalk.com.
DHCP Option 42 override NTP server	Select Yes for the user to allow DHCP Option 2 to override the NTP server if there is one on the LAN. The default setting is NO.
Time Zone	This parameter controls the date/time display according to the specified time zone.
Time Display Format	This parameter sets time display format to 12 Hour or 24 Hour
Date Display Format	This parameter sets date display format to YY-MM-DD or MM-DD-YY or DD-MM-YY.
Self-Defined Time Zone	This parameter allows the users to define their own time zone. Syntax: std offset dst [offset], start [/time], end [/time] Default is set to: MTZ+6MDT+5,M3.2.0,M11.1.0, MTZ+6MDT+5 This indicates a time zone with 6 hours offset with 1 hour ahead which is U.S central time. If it is positive (+) if the local time zone is west of the Prime Meridian (A.K.A: International or Greenwich Meridian) and negative (-) if it is east. M3.2.0,M11.1.0 The 1st number indicates Month: 1,2,3..., 12 (for Jan, Feb, ..., Dec) The 2nd number indicates the nth iteration of the weekday: (1st Sunday, 3rd

	<p>Tuesday...)</p> <p>The 3rd number indicates weekday: 0,1,2,...,6(for Sun, Mon, Tues,...,Sat)</p> <p>Therefore, this example is the DST which starts from the second Sunday of March to the 1st Sunday of November.</p>
--	--

Maintenance/Web and Telnet Access

Disable Telnet	The default value is No. If set to YES, the GXV3175 will not allow any telnet access to the phone.
Access Method	This defines the access method for web access: HTTP or secure HTTPS protocol.
Port	This defines the port for web access. By default, HTTP uses port 80 and HTTPS uses port 443. This field is for customizable web ports.
Admin Password	This defines the administrator password for web interface access. Only the administrator can configure the “Advanced Settings” and “Account x” pages. The password is case sensitive and the maximum password length is 25 characters.
User Password	This defines the user password for web interface access.

Maintenance/Upgrade

Lock Keypad for Update	The default value is NO. If set to YES, the keypad will be disabled from making any updates.
XML Config File Password	The password used for encrypting the XML configuration file using OpenSSL. This is required for the phone to decrypt the encrypted XML configuration file.
HTTP/HTTPS User Name	The user name for the HTTP server.
HTTP/HTTPS Password	The password for the HTTP server.
Upgrade Via	This field allows the user to choose the firmware upgrade method: TFTP, HTTP or HTTPS.
Firmware Server Path	Defines the server path for the firmware server. It can be different from the Configuration server which is used for provisioning.
Config Server Path	This is the server path for provisioning; it can be different from the firmware server.
Firmware File Prefix	This field enables your ITSP to lock firmware updates. If configured, only the firmware with the matching encrypted prefix will be downloaded and flashed

	into the phone.
Firmware File Postfix	This field enables your ITSP to lock firmware updates. If configured, only the firmware with the matching encrypted postfix will be downloaded and flashed into the phone.
Config File Prefix	This field enables your ITSP to lock configuration updates. If configured, only the configuration file with the matching encrypted prefix will be downloaded and flashed into the phone.
Config File Postfix	This field enables your ITSP to lock configuration updates. If configured, only the configuration file with the matching encrypted postfix will be downloaded and flashed into the phone.
DHCP Option 66 override Server	The Default setting is YES. If DHCP option 66 is enabled on the LAN side, the TFTP server can be redirected. Please be very careful when configuring this as the redirection could break the phone if this happens during the firmware upgrade.
Automatic Upgrade	The default value is NO. Choose "YES" to enable automatic HTTP upgrade and provisioning.
Period time of upgrade checking	Specifies the time period to check for firmware upgrade. The default setting is 10080 minutes (7 days)
Hour of the day (0-23)	Defines the hour of the day to check the HTTP/TFTP server for firmware upgrades or configuration files changes.
Day of the week (0-6)	Defines the day of the week to check the HTTP/TFTP server for firmware upgrades or configuration files changes.
Automatic Upgrade Rule	Defines the rules for automatic upgrade: Always Check, when F/W suffix/prefix changes, Skip the Firmware Check.
Authenticate Conf File	Authenticate configuration file before acceptance. The Default setting is NO.
Factory Reset	Restore to factory default settings. Users can choose from: Full Reset, VoIP Data Reset, and User Data Reset. After the selection is made, press the "Reset" button to factory reset the phone. NOTE: Users can use the backup/restore functionality of the phone prior to the factory reset.

Maintenance/Syslog

Syslog Server	The URL/IP address for the syslog server.
Syslog Level	Select the level of logging for syslog. The default setting is NONE.

	<p>There are 4 levels: INFO, DEBUG, ERROR and WARNING.</p> <p>Syslog messages are sent based on the following events:</p> <ul style="list-style-type: none"> Product model/version on boot up (INFO level) NAT related info (INFO level) Sent or received SIP message (DEBUG level) SIP message summary (INFO level) Inbound and outbound calls (INFO level) Registration status change (INFO level) Negotiated codec (INFO level) Ethernet link up (INFO level) SLIC chip exception (WARNING and ERROR levels) Memory exception (ERROR level).
--	---

Maintenance/Debug

Capture Trace	Press START to start capturing a trace, and press STOP to abort the capture process.
View Trace	Press LIST to view the list of captured traces. It will show the time the trace was captured. Click on the name of the file to download and view the trace.
Enable Application Debug	When set to YES, the trace captured will contain debug messages. The default setting is NO.

Maintenance/Language

Language	Selects the language setting for the phone. The current version supports English, Traditional Chinese and Simplified Chinese.
----------	---

Maintenance/Network Manager

ACS URL	Enter URL for TR-069 Auto Configuration Servers (ACS)
ACS Username	Enter ACS username
ACS Password	Enter ACS password
Periodic Inform Enable	Enable periodic inform. By default, it is disabled
Periodic Inform Interval(s)	Enter periodic inform interval(s). By default, it is set to 300s.
Connection Request Username	Enter connection request username

Connection Request Password	Enter connection request password
-----------------------------	-----------------------------------

Maintenance/OpenVPN Settings

OpenVPN Enable	This enables/disables OpenVPN functionality. The default setting is No. To use OpenVPN functionality, it requires user to have access to an OpenVPN server.
OpenVPN Server Address	The URL/IP address for the OpenVPN server.
OpenVPN Server Port	The network port for the OpenVPN server. By default, it is set to 1194.
OpenVPN CA	OpenVPN CA file (ca.crt) required by the OpenVPN server for authentication purposes. Press "Upload" to upload the corresponding file to the phone.
OpenVPN Client Certificate	OpenVPN Client certificate file (*.crt) required by the OpenVPN server for authentication purposes. Press "Upload" to upload the corresponding file to the phone.
OpenVPN Client Key	The OpenVPN Client key (*.key) required by the OpenVPN server for authentication purposes. Press "Upload" to upload the corresponding file to the phone.

NOTE: To use OpenVPN functionalities, users must enable OpenVPN and configure all of the settings related to OpenVPN, including server address, port, OpenVPN CA, certificate and key. Additionally, the user must also set the SIP account to use "VPN" for the "Nat Traversal" (under Account-> Network Settings). Reboot the phone after these settings are saved for the changes to take effect. Once the phone connects to the OpenVPN server and the authentication is correct, the phone will show the VPN IP address under the Status-> Network Status, but it will still display the LAN IP on the LCD of the phone.

Maintenance/Device Manager (LCD)

Screen Saver Timeout (m)	This sets the lapsed idle time needed for the screen saver to appear. The default setting is 5 minutes.
Screen Saver Interval (s)xd	The screen saver is a picture slide show. This defines the frequency to change the picture on the screen for the screen saver. The default setting is 10 seconds.
LCD Auto Power Off Time (m)	This defines the lapsed idle time needed for the LCD to power off automatically in order to save power. The default setting is 10 minutes.

Maintenance/Device Manager (Headset)

Headset TX Gain (dB)	Transmission gain. It's a headset setting to control the voice intensity. The default setting is 0dB.
Headset RX Gain (dB)	Receive gain. It's a headset setting to control the voice intensity. The default setting is 0dB.

Maintenance/Device Manager (Camera)

Zoom mode	Select the desired camera zoom mode (Tele, optical, digital). Can adjust local video zoom either in mirror mode or during the call (on the fly) by pressing the Left or Right Arrow Key.
Exposure Setting	Select the desired Camera Exposure mode based on the surroundings. The default setting is set to Auto. The default setting is 8.
Color Mode	Select the desired Camera Color Mode (Color or Monochromatic). The default setting is set to Color.
White Balance	Select the desired Camera White Balance to be automatic or Fixed. The default setting is set to Auto.
Lens Correction	Correct Camera Lens noise. The default setting is set to YES. It is recommended to set this parameter to YES to reduce camera lens noise and improve video quality.
Flicker Control	Reduces flicker of image shot with a video camera caused by luminance fluctuation of an illuminating light source. Users can select 50Hz/60Hz depending on the frequency of the commercial electrical power. The default setting is set to Auto.

Maintenance/Device Manager (TV Port)

TV Output	Select the desired TV Output type (PAL or NTSC). NTSC 4:3 by default.
-----------	---

SIP ACCOUNT CONFIGURATION PAGE DEFINITIONS

The GXV3175 has three lines that can be configured to accommodate independent SIP accounts. Every SIP account has an individual configuration page.

Account/General Settings

Account Active	Select YES to enable and use the Line.
Account Name	The account name for the user that is displayed on the LCD screen.
SIP Server	The IP address of the SIP server or the given domain name of the VoIP

	service provider.
SIP User ID	User account information provided by the VoIP service provider; normally similar to a telephone number or an actual telephone number.
Authenticate ID	The authenticate ID for the SIP user. It can differ or be the same as the SIP user ID.
Authenticate password	The password that the GXV uses to authenticate with the ITSP (SIP) server. After it is saved, this will appear as blank for security reasons. The maximum length is 25 characters.
Voice Mail User ID	When this is configured, the user can dial to the voicemail server using the MESSAGE button. This ID is normally the feature code for Voice Mail.
Name	The Caller ID that will be displayed for the account.
Tel URI	The default setting is "Disable". If the Video phone has an assigned PSTN number, this field should be set to "Enable". If "User=Phone" is set, a "User=Phone" parameter will be attached to the "From header" in the SIP request to indicate the E.164 number.

Account/Network Settings

Outbound Proxy	IP address or Domain name of the Outbound Proxy, or Media Gateway, or Session Border Controller. Used by the GXV3175 for firewall or NAT penetration in different network environments. If a symmetric NAT is detected, STUN will not work and ONLY an Outbound Proxy will work.
DNS Mode	The default is set to A Record. If the user wishes to locate the server by DNS SRV, the user may select SRV or NATPTR/SRV.
NAT Traversal	<p>This setting decides whether the NAT traversal mechanism is activated. If it is set to "STUN" and STUN server is configured, the GXV3175 will route according the STUN server. In this mode, the STUN client embedded in the phone will communicate with the appointed STUN server to examine which type of Firewall/NAT setting is employed. If the type of NAT detected is Full Cone, Restricted Cone or Port-Restricted cone, the phone will try to use public IP addresses and port in all the SIP and SDP messages.</p> <p>If the "NAT Traversal" is configured to be "Keep-alive", the phone will send an empty SDP packet (without payload data) to the SIP server once in 20 seconds to keep the NAT port open.</p> <p>If VPN is used, users should select "VPN" for NAT Traversal.</p> <p>Users could also set "Auto" or "UPnP" according to the network configuration.</p> <p>If an outbound proxy server is used, please configure this to be "NAT NO".</p>

Proxy Require	Notifies the SIP server that the unit is behind a NAT/Firewall.
---------------	---

Account/SIP Settings

SIP Registration	Selects whether or not the GXV3175 will send a SIP Register message to the proxy; The default setting is YES.
Unregister On Reboot	If set to YES, the SIP user registration messages will be cleared on reboot. The default setting is YES.
Register Expiration (m)	This defines the expiration time of the registration in minutes. The default value is 50 minutes; the maximum value is 65535 minutes (approximately 45 days) and the minimum value is 5 minutes.
Wait Time Retry Registration (s)	The wait time for registration retry if registration fails. The default is set to 20 Seconds.
Local SIP Port	The local SIP port for sending and receiving data. The default settings for Account 1/2/3 are 5060/5062/5064.
Subscribe for MWI	Default is set to No. When selected, a SUBSCRIBE for Message Waiting Indication will be sent out periodically.
Session Expiration (s)	Session Expiration is the time (in seconds) at which the session is considered timed out if no successful session refresh transaction occurs beforehand. The default value is 180 seconds.
MIN-SE (s)	The minimum session expiration (in seconds). The default value is 90 seconds.
UAC Specify Refresher	As a Caller, select UAC to use the phone as the refresher, or select UAS to use the Callee or proxy server as the refresher.
UAS Specify Refresher	As a Callee, select UAC to use the caller or proxy server as the refresher, or select UAS to use the phone as the refresher.
Force INVITE	The Session Timer can be refreshed using the INVITE or UPDATE methods. Select "Yes" to use the INVITE method to refresh the session timer
Caller Request Timer	The default setting is Yes. If Yes is selected, the phone will use the session timer when it makes outbound calls if remote party supports session timer.
Callee Request Timer	If Yes is selected, the phone will use the session timer when it receives inbound calls with session timer request.
Force Timer	If Yes is selected, the timer will be activated even if the other party does not support session timers. If No is selected, the timer will be activated only if the other party supports the timer. To disable the timer, Caller Request timer, Callee request timer and Force Timer should all be set to No.
Enable 100rel	The use of the PRACK (Provisional Acknowledgment) method enables

	reliability to SIP provisional responses (1xx series). This is very important in order to support PSTN internetworking. To invoke a reliable provisional response, the 100rel tag is appended to the value of the required header of the initial signaling messages. The default setting is No.
SIP Transport	Selects the SIP transport method. There are three types: TCP, UDP and TLS.
Symmetric RTP	Selects whether or not symmetric RTP is supported.
Support SIP Instance ID	Selects whether or not SIP Instance ID is supported.
Validate Incoming Messages	This configuration selects whether or not the incoming messages should be validated.
SIP T1 Timeout	This configures the timeout period for SIP T1. The default setting is 0.5 Seconds.
SIP T2 Interval	This configures the time interval for SIP T2. The default setting is 4 seconds.
Remove OBP from route	The SIP Extension notifies the SIP server that it is behind a NAT/firewall.

Account/Codec Settings

Enable Video	--YES: Accepts all incoming video, this is the default setting; --NO: video is disabled. --Enable/Disable during dialing: Dialing time choice to enable/disable video
DTMF	Assigns the mechanism to send DTMF. There are three supported modes: in audio (with DTMF as audio signals), through RTP and through SIP INFO.
DTMF Payload Type	Sends DTMF using RFC2833. The default is 101.
Preferred Vocoder	This products supports up to 8 different Vocoders: including G.711(a/μ)(PCMU/PCMA),GSM,G726-32,G.723.1,G.729A/B, G.722 and L16-256. When this has been configured, the system will select the preferred vocoder from the list and the same order is sent with the SDP messages. The user can change the preferred vocoder priority order by toggling with the up and down buttons. It is recommended to use the default setting "PCMU"; if other vocoders are chosen, there could be an audio transmission error.
Preferred Video Codec	Selects the preferred video codec from the available list. It is recommended to use H.264.
H.264Payload type	Selects the dynamic H.264 codec payload type (ranges from 96-127). The default setting is 99.

H.263+ Payload type	Selects the H.263+ codec payload type (ranges from 96-127). The default setting is 103.
L16-256 Payload type	Selects the L16-256 codec payload type (ranges from 96-127). The default setting is 103.
H.263 Encoder Resolution	Selects the resolution (CIF/QCIF) used for H.263 codec. The default resolution is CIF.
Silence Suppression	This controls the G723/G729 silence suppression/VAD. If set to YES, when no audio is detected, the phone will send a small number of VAD packets (instead of audio packets). If Set to NO, this feature is disabled. The default setting is NO.
Voice Frame per TX	<p>This configures the number of voice frames transmitted per packet. (It is recommended to set this based on the Ethernet IS packet limitation – 1500 Byte or 120kb/s).</p> <p>When configuring this, it should be noted that the “ptime” value for the SDP will change with different configurations here. This value is related to the codec used and the actual frames transmitted during the in payload call.</p> <p>For example: if the codec is configured to be G.723 and “Voice Frames per TX” is set to 2. Then in the INVITE request, the “ptime” value for SDP will be 60 ms. This is because the G723 voice frame is 30 ms. Similarly, if the setting is 2 and the codec is G729 or G711 or G726, the “ptime” value for SDP in the INVITE request will be 20 ms.</p> <p>If the voice frames per TX configuration exceeds the maximum value allowed, the phone will choose the preferred codec and use the maximum value allowed.</p> <p>The maximum value is 64 frames.</p> <p>Adjusting these values will also change the jitter buffer. The phone has an algorithm for setting the jitter buffer and the jitter buffer rate is around 20-200ms.</p> <p>For end-users, it is recommended to use the default setting, as incorrect settings may influence the quality of audio.</p>
G723 Rate	This defines the encoding rate for G723 vocoder, and can be 6.3Kb/s or 5.3Kb/s. Please confirm with your service provider.
Jitter Buffer Type	Users can select either Fixed or Adaptive based on network conditions. The default is Adaptive.
Jitter Buffer Length	User can select Low, Medium, or High based on network conditions. The default is Medium.

Account/Call Settings

Dial Plan Prefix	Sets the prefix added to each dialed number.
Dial Plan	<p>Dial Plan Rules:</p> <ol style="list-style-type: none"> 1. Accepted Digits: 1,2,3,4,5,6,7,8,9,0 , * , #, A,a,B,b,C,c,D,d 2. Grammar: x - any digit from 0-9; <ol style="list-style-type: none"> a) xx+ - at least 2 digit numbers b) xx. - only 2 digit numbers c) ^ - exclude d) [3-5] - any digit of 3, 4, or 5 e) [147] - any digit of 1, 4, or 7 f) <2=011> - replace digit 2 with 011 when dialing g) - the OR operand <ul style="list-style-type: none"> • Example 1: {[369]11 1617xxxxxxx} <p>Allow 311, 611, and 911 or any 10 digit numbers with leading digits 1617</p> <ul style="list-style-type: none"> • Example 2: {^1900x+ <=1617>xxxxxxx} <p>Block any number of leading digits 1900 or add prefix 1617 for any dialed 7 digit numbers</p> <ul style="list-style-type: none"> • Example 3: {1xxx[2-9]xxxxxx <2=011>x+} <p>Allows any number with leading digit 1 followed by a 3 digit number, followed by any number between 2 and 9, followed by any 7 digit number OR Allows any length of numbers with leading digit 2, replacing the 2 with 011 when dialed.</p> <ol style="list-style-type: none"> 3. Default: Outgoing – {x+} <p>Allow any length of numbers.</p> <p>Example of a simple dial plan used in a Home/Office in the US: { ^1900x. <=1617>[2-9]xxxxxx 1[2-9]xx[2-9]xxxxxx 011[2-9]x. [3469]11 }</p> <p>Explanation of example rule (reading from left to right):</p> <ul style="list-style-type: none"> • ^1900x. - prevents dialing any number started with 1900 • <=1617>[2-9]xxxxxx - allows dialing to local area code (617) numbers by dialing 7 numbers and 1617 area code will be added automatically • 1[2-9]xx[2-9]xxxxxx - allows dialing to any US/Canada Number with 11 digits length

	<ul style="list-style-type: none"> • 011[2-9]x. - allows international calls starting with 011 • [3469]11 - allow dialing special and emergency numbers 311, 411, 611 and 911 <p>NOTE: In some cases where the user wishes to dial strings such as *123 to activate voice mail or other applications provided by their service provider, the * should be predefined inside the dial plan feature. An example dial plan will be: { *x+ } which allows the user to dial * followed by any length of numbers.</p>
Early Dial	The default setting is NO. Use only if the proxy supports 484 response.
Refer to Use Target Contact	The default is NO. If set to YES, then for Attended Transfer, the “Refer-To” header uses the transferred target’s contact header information.
Auto Answer	The default setting is NO. If it is set to YES, the GXV3175 will play a “beep” sound and answer the phone automatically on the speaker.
Send Anonymous	If set to YES, the “From” header in the outgoing SIP messages will be set to anonymous to block the caller ID from displaying. The default setting is NO.
Anonymous Call Rejection	The default setting is NO; If set to YES, any anonymous call will be rejected (with 486 Busy message)
Special Feature	Different soft switch vendors have special requirements; therefore users may need to select special features to meet these requirements. Users can choose from Standard, CBCOM, RNK, China Mobile, ZTE IMS and Mobotix depending on their need. The default setting is Standard.
Enable Call Features	The default is set to YES. If it is set to NO, call features are disabled.
Call Forward Unconditional	Sets the number to forward to unconditionally.
Call Forward When Busy	Sets the number to forward to when busy.
Call Forward When No Answer	Sets the number to forward to when no answer.
Delayed Call Forward Wait Time (s)	The wait time before transferring the call to another extension or to voicemail; the default setting is 20 seconds.
No Key Entry Timeout (s)	Defines the time out duration on no key entry. Default setting is 4 seconds.
Ring Timeout (s)	Defines the time out duration on no answer. Default setting is 60 second.
Transfer on Conference Hangup	Defines whether or not the call is transferred to the other party if the initiator of the conference hangs up. Default setting is set to No.

Use # as Dial Key	Selects whether or not # is used as Send.
Account ring tone	This allows the user to configure the general ringtone used for this account. Users can choose from different ringtones from the dropdown menu. They can also upload mp3 files in Ringtone manager for their own ringtone.
Ring Tone	Users can select up to 3 distinctive ringtones to match incoming caller ID. Users can choose from different ringtones from the dropdown menu. They can also upload mp3 files in Ringtone manager for their own ringtone.

SAVING THE CONFIGURATION CHANGES

After users makes changes to the configuration, press the “Save” button in the Configuration Menu. The web browser will then display a message window to confirm the saved changes. Reboot the phone for the new settings to take effect if the settings that you have changed have a dot next to it.

REBOOTING FROM REMOTE LOCATIONS

Press the “Reboot” button at the top right-hand corner of the configuration menu to reboot the phone remotely. The web browser will then display a message window to confirm with the user if they wish to reboot the phone or not. Click on “Yes” and the phone will reboot. Wait approximately 2 minutes to log in again.

LCD MENU AND FEATURES

The GXV3175's user-friendly LCD MENU provides easy access to a host of features and convenient tools to help simplify the users' business and personal life. Essentially, the GXV3175 can act like a personal assistant in many ways. In this section, we'll explore the LCD MENU and Features and explain how users can take full advantage of the GXV3175's capabilities.

CONTACTS

Users can easily manage all the contacts through CONTACTS. CONTACTS supports total records up to 500 entries and 20 groups with features such as add/delete/modify contacts, download phone book from the TFTP/HTTP server as well as the ability to save the phonebook to the PC. Select MENU-> CONTACTS and it will display in the figure below.

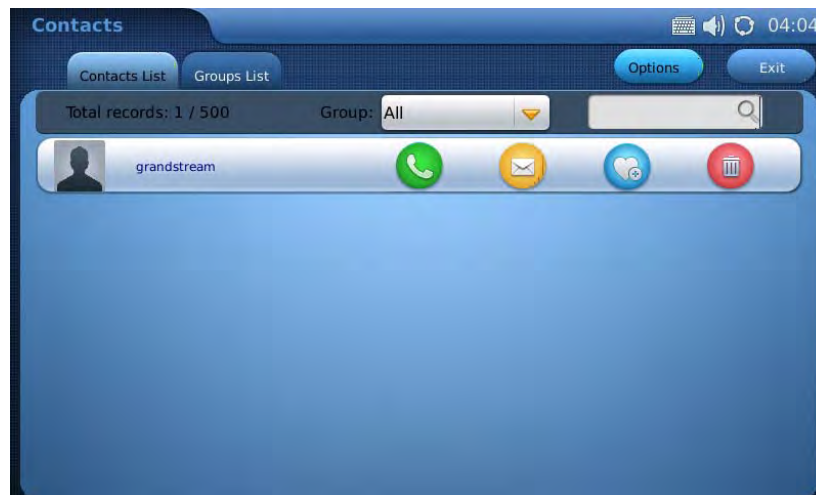








Figure 34: CONTACTS

Select "Contact List" or "Group List" tab to view/edit contact or group information.

In "Contact List", users could select the group to view all the contacts in it. To search the contact by name, tap on the blank area besides  to input the name using the soft keyboard. In one entry in the contact list, press the icon  to make a call, press  to send short message, press  to add the contact to favorite and press  to delete. Select and Tap on one contact entry then the users could view the full contact information.

To add new contact, press the "Options" button and select option "New". Then the screen will show as

Figure 35.

Every contact contains Work number, Home number, Mobile number and Fax number for a specific account. By tapping on the blank area in the field, the soft keyboard will be activated for input. If the number is set to primary number, it will be dialed out when  is pressed in Figure 34. Thumbnail Image, ringtone could be customized to associate with each contact. Users could select from the dropdown list by pressing the “Down” arrow or browser to add ringtone file or picture from local or external storage device.

Press the “Down” arrow to select the group for the contact and press “Edit” to edit the group information. After finishing editing the contact, press “Save”.



Figure 35: Adding a new contact

To import/export contacts, in the screen shown as Figure 34, select “Options”->“Import/Export”. Then in the screen shown as Figure 36, select “Import” or “Export” in “Operation Mode”.



Figure 36: Import/Export contact list

There are three types of File to be selected: “XML”, “CSV” and “VCard”. For “Import”, users could select to “Clear The Old List” and “Replace Duplicate Items” in the imported files. If the operation mode is “Import”, users will need press on “Browse” button to specify the imported file from local or external storage device. Press “Import/Export” to finish the operation.

In addition to manually adding each phonebook entry, the GXV3175 enables users to share and maintain the phonebook (by means of a XML phonebook) through the web easily. The XML phonebook must be stored on a HTTP/TFTP server. There are also applications where organizations will want to have a centralized directory server and have all phones in the organization synchronize with the server periodically.

To access this feature, in the screen shown as Figure 34, select “Options”->“Download”. Then in the screen shown as Figure 37, select “OFF”, “TFTP” or “HTTP” in “Download Mode”.



Figure 37: Download phonebook.xml

Users could also select to “Clear The Old List” and “Replace Duplicate Items” in the downloaded phonebook. Tap on the blank field in “Download Server” to input the server URL using the soft keyboard. If “Download Interval (Min)” is set, the device will send request for the phonebook in the server for automatic update. After the setting, users could press “Download Now” for immediate download or press “OK” to finish the operation.

To delete all the contacts, users could select “Options”->“Delete All” in Figure 34.

CALL HISTORY

GXV3175 supports call record up to 100 dialed calls, 100 received calls and 100 missed calls. Users may access the phone’s call records through “MENU” -> “Call History”. See Figure 38.

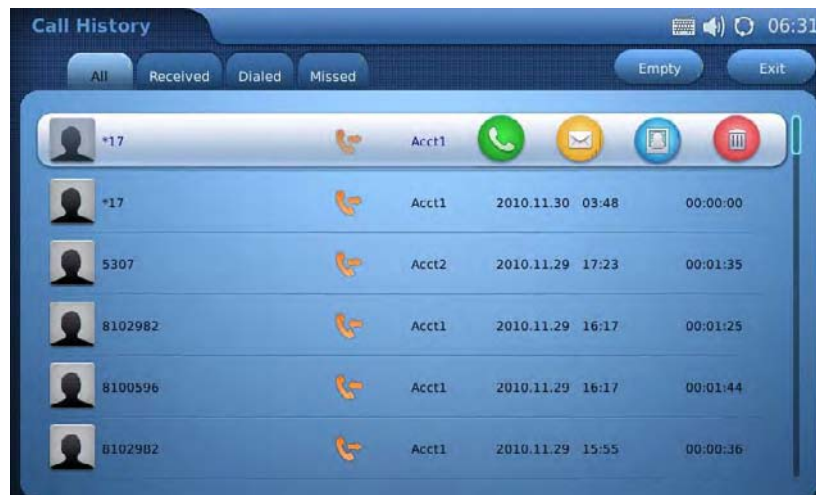






Figure 38: Call History

Users could select among the four tabs “All”, “Received”, “Dialed” and “Missed” to access the corresponding call record.

For each record, users can choose to Call , Message , Edit and Save to Contacts  or Delete  by pressing the icon. To delete all the call records in one page, tap on the “Empty” button.

MESSAGES

Messages is a text message feature in GXV3175. If two GXV3175s are registered on the same SIP server, text messages can be sent/received between two parties. Similarly, if other IP products support this feature,

the text message feature can also be used to send/receive messages between the device and the GXV3175. This application is accessible by selecting “MENU”-> “Messages”.

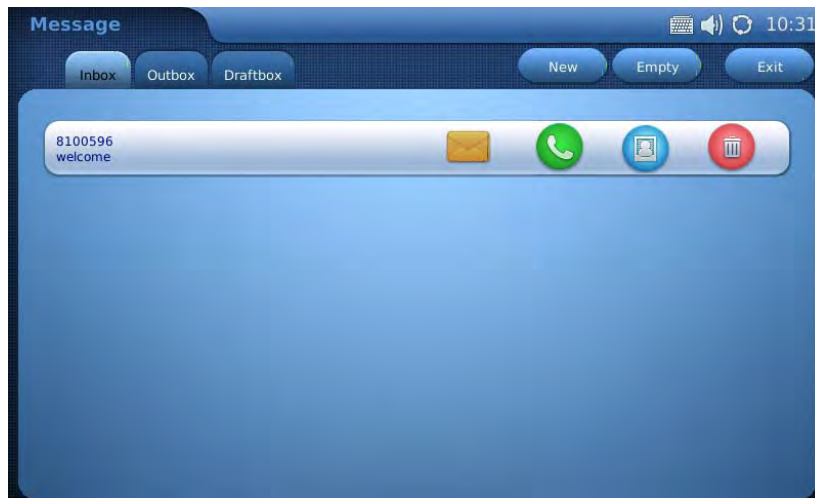






Figure 39: Message Inbox

In Messages, there are three categories “Inbox”, “Outbox” and “Draftbox” for users to select to view and manage the messages.

For each message, users press  to view the message, press  to dial the number out, press  to edit and save the contact, or press  to delete the message.

To send message, press “New” button. In Figure 40, edit the message by tapping on the blank area in the message content.

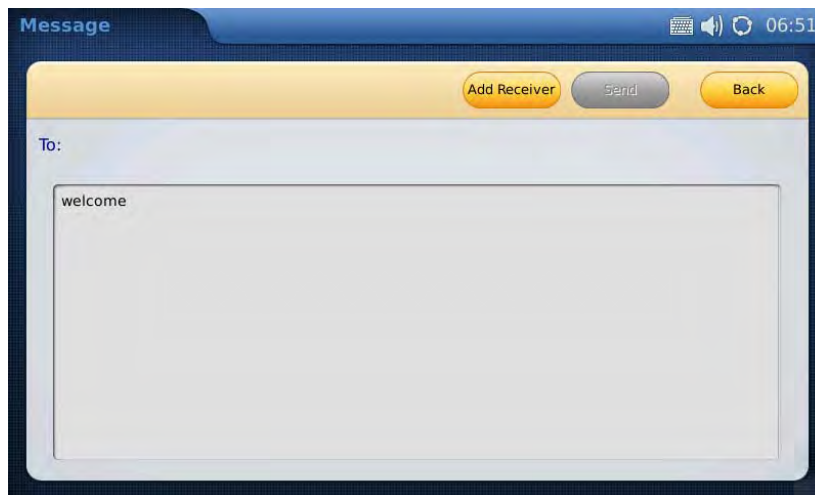


Figure 40: Edit new message

Then press “Add Receiver” to add the number in the window as shown in Figure 41. Users should choose the account from which the message will be sent out. After that, enter the phone number by tapping on the blank area in “Phone Number” field then press the activated “Add” button. Or simply press “Find in Contacts” button to add the number from contact list.



Figure 41: Add receiver’s number

After pressing “Find in Contacts” button, users will see the screen as Figure 42 shows. The primary number for the contact will show in the list by default. If the users need to change to non-primary number,

press  to add other numbers in the contact. Press  to add the number as message receiver.

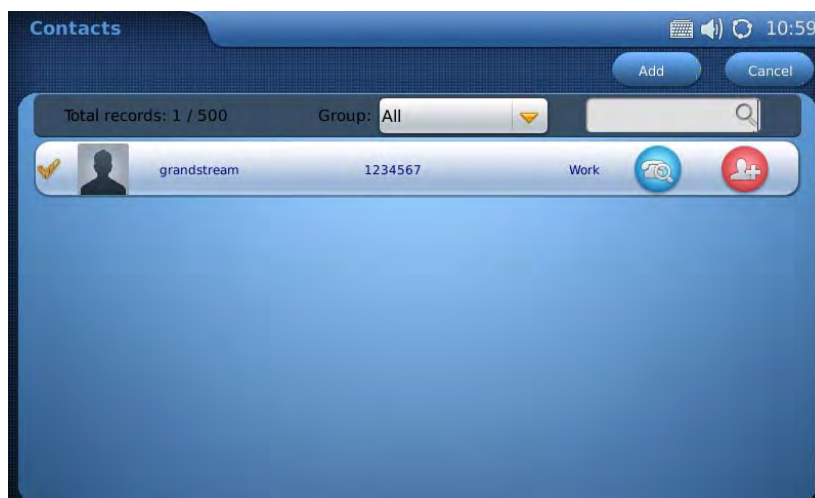



Figure 42: Add receiver’s number from contact list

A yellow check will show on the left of the contact after pressing . Now tap on “Add” button and the screen will show in Figure 43.

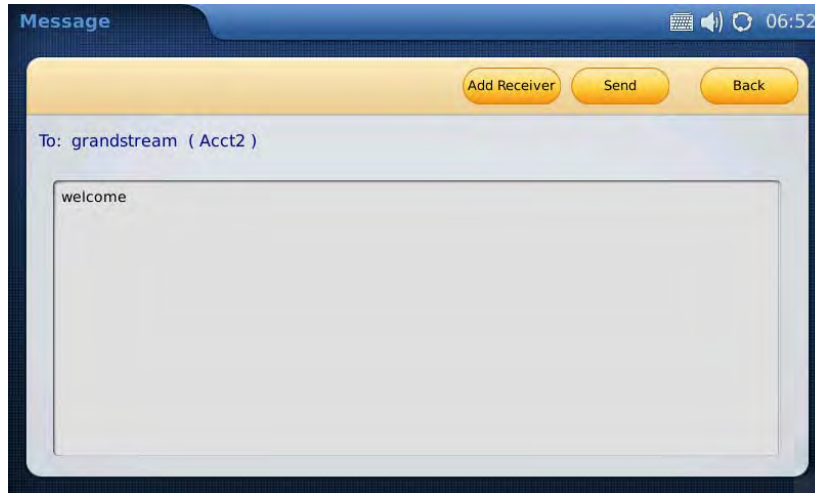


Figure 43: Send out message

The “Send” button will be activated after the message text and receiver are added successfully. Press “Send” to send the message out.

To view and reply message, select “Inbox” or press “View” in the incoming message alert window. (See Figure 44)

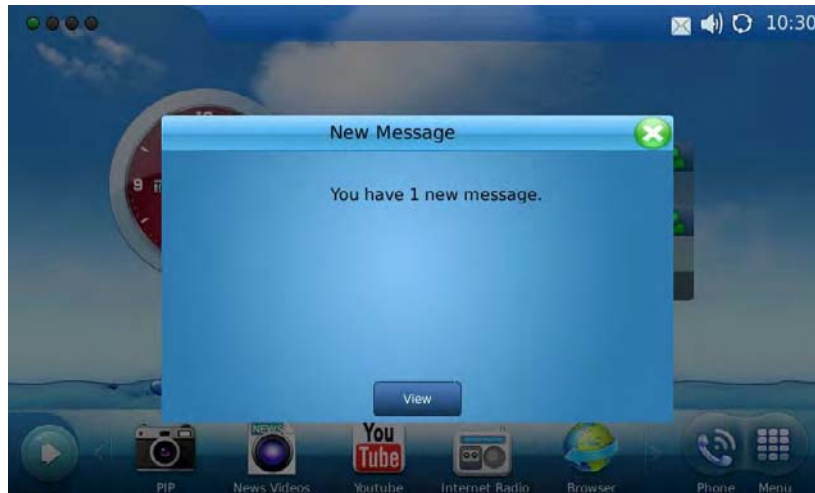


Figure 44: New message alert

To reply or forward the received message, press “Reply” or “Forward” in the Figure below.

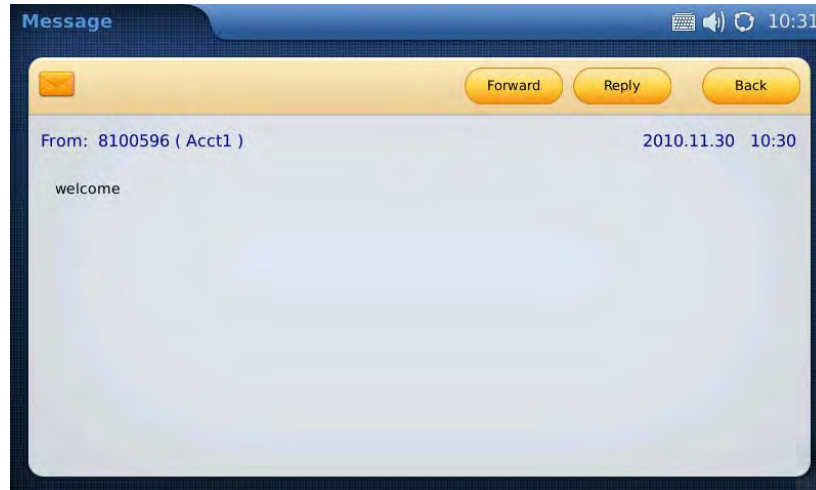


Figure 45: Incoming message

To delete all the messages, press “Empty” button in Figure 39.

SOCIAL NETWORKS

- Google Voice

The GXV3175 IP Multimedia Phone supports Google Voice to enable the user to enjoy the social connections. Google Voice application in GXV3175 enables the users to make calls, send messages, manage contacts and account after logging in Google Voice account.

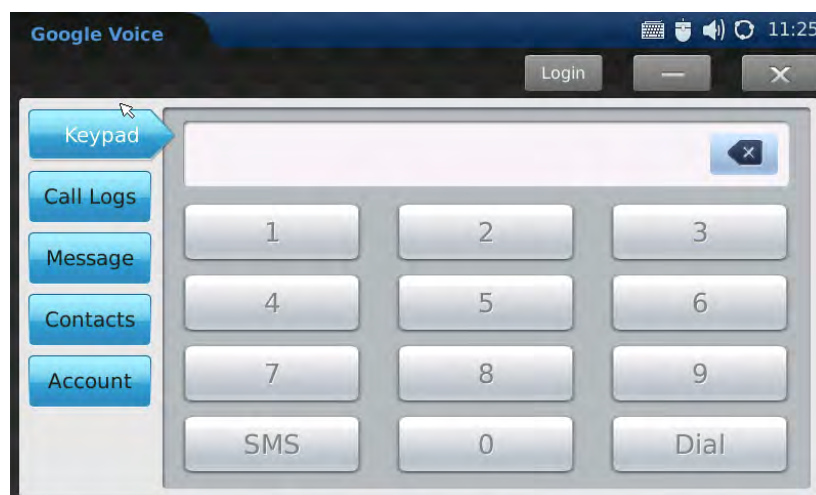


Figure 46: Google Voice in GXV3175

In Figure 46, press “Login” button and enter Email and Password via soft keyboard in Figure 46. Then

Click “Login” in the login window.

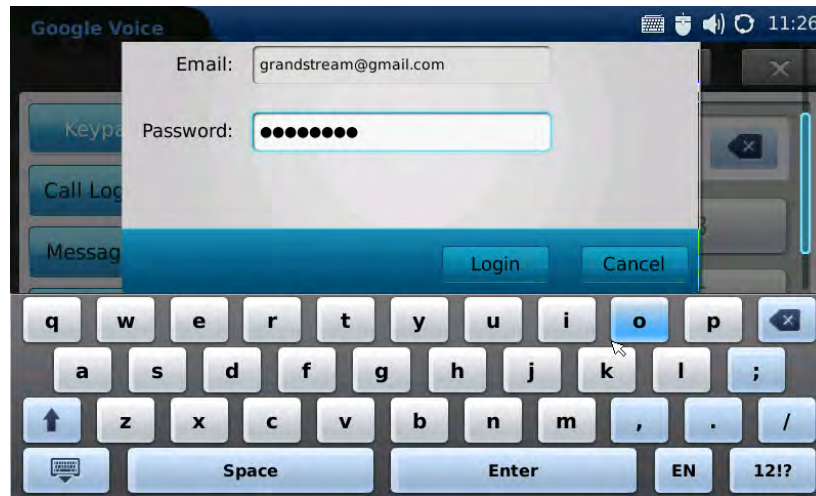



Figure 46: Login Google Voice Account



Figure 47: Using Google Voice in GXV3175

After logging in, users could tap on the number of the keypad shown in Figure 47. Then press “Dial” to make a call. Press “SMS” to send messages.

To view the call history, press “Call Logs” in the menu on the left of the screen and press the refresh icon . See Figure 48. Users will be able to dial out or send message to the contact in Call Logs by tapping on the selected entry in the displayed list.

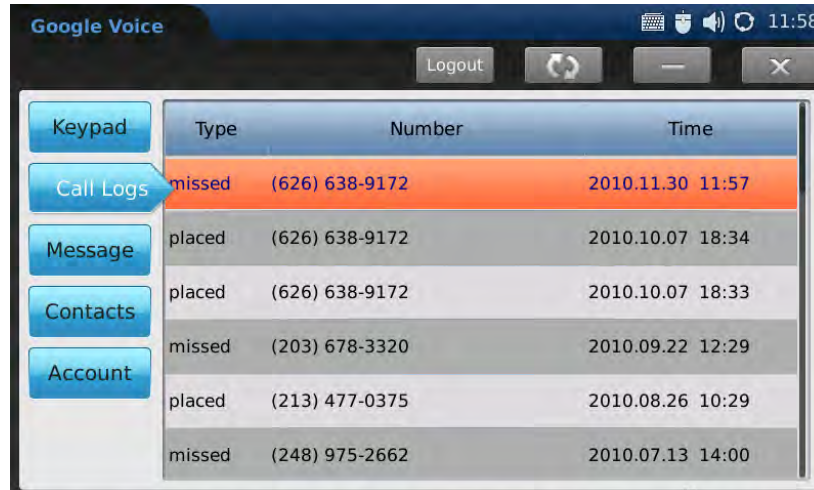



Figure 48: Google Voice-> Call Logs

To view messages, press “Message” and the refresh icon . (See Figure 49). Select and press on one of the messages to reply the message or dial out. The maximum letters allowed in the message is 160.

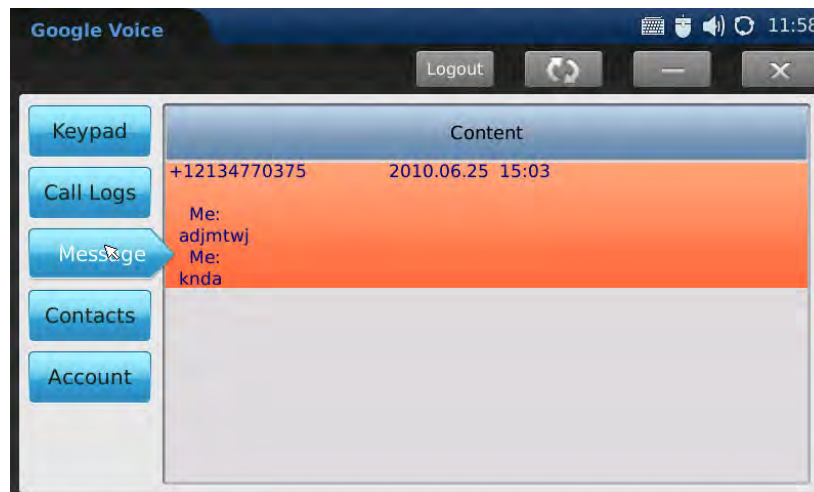


Figure 49: Google Voice-> Messages

To view the contacts set in google voice account, press “Contacts” and a list of contacts will show up in the screen. Users could also call or send messages to selected contact here by choosing one entry and tapping on it. See Figure 50.

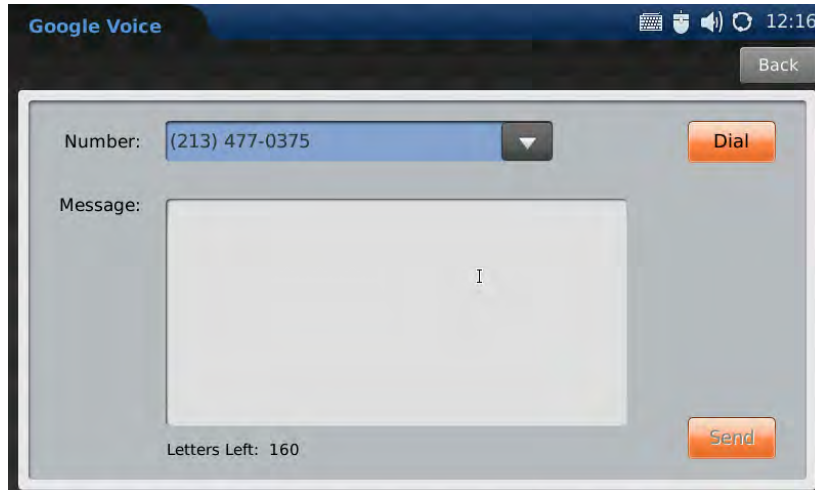


Figure 50: Google Voice-> Contacts

To setup Callback Number for the account, press “Account” and tap on the “Down” arrow to select the number from the dropdown list. See Figure 51.

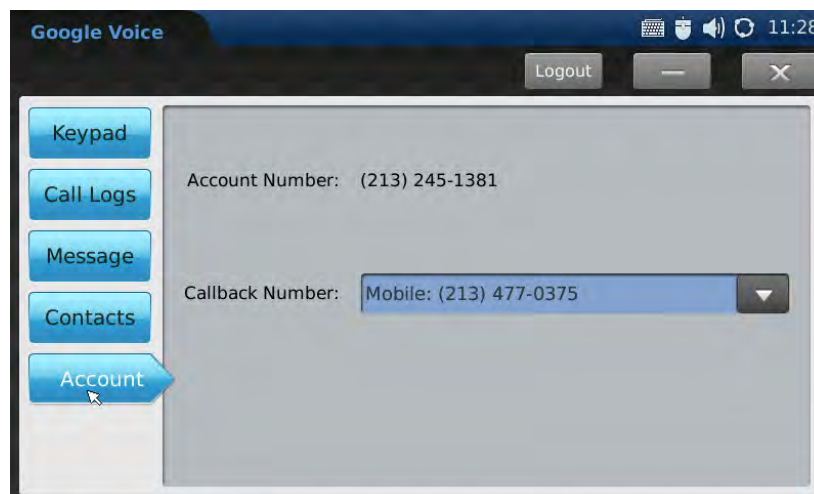




Figure 51: Google Voice Account Settings

To logout Google Voice account, press “Logout” and select “Yes” in the popping out message “Are you sure to logout?” Users could also minimize Google Voice and use other applications on GXV3175 at the same time without logging out by pressing icon . Press icon  to exit Google Voice.

BROWSER

The GXV3175 has a full HTML Web Browser for Internet browsing. The web browser is accessible by selecting “MENU”-> “Browser”. Tap on the blank area in navigation bar to enter the URL via soft keyboard and press “Enter” in the keyboard to visit the website. See Figure 52.



Figure 52: GXV3175 Web Browser





Users can view the web page by holding the finger and dragging in the touchscreen. Press icon  to move backward and  to move forward. Figure 53 shows the screen of the web browser while visiting Grandstream website.



Figure 53: Using the GXV3175 Web Browser

While browsing the website, users can press icon  to refresh the webpage. To exit web browser, press .

MUSIC



To utilize the GXV3175's Online Music streaming application, users could access Internet Radio and Last.fm via "MENU"->"Music".

- **INTERNET RADIO**



The GXV3175 has a built-in Internet Radio application with thousands of radio channels from all over the world. The channels are divided into these categories: Favorite, Local, Talk, Music, Sports and World.



Figure 54: Menu->Music->Internet Radio

As shown in Figure 54, users can select one of the channels according to their preference. Then toggle through the channel list using scroll bar and select one channel. Press  or  to play or stop the selected program. Scroll the volume bar to adjust the volume.

To change the audio output, press "Options" button down in the left corner. Then press "Output" and select "Speaker", "Headset" or "Stereo".

To add the channel to "Favorite" list, select one channel then press  icon to add it to "Favorite". Users can also specify a channel to add in "Favorite" by pressing . In Figure 55, enter the Radio Name and Radio URL via soft keyboard by tapping on the blank field. Then press "OK".

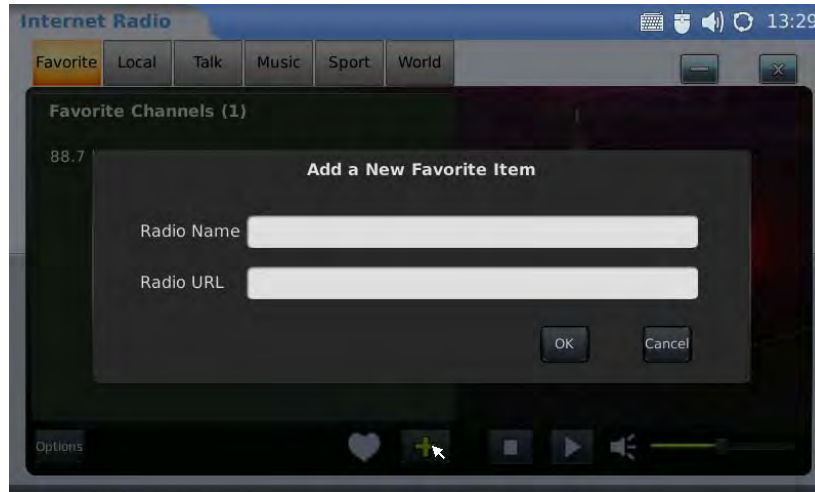



Figure 55: Internet Radio->Add Radio to Favorite

To close Internet Radio, press  to minimize the application and press  to exit.

- Last.fm

Last.fm is a social platform for users to select preferred music genre, share and listen to it online. Users must have a pre-existing account with Last.fm before listening to online music. Users could login the Last.fm account after registration via www.last.fm or on the phone following the instructions.

After the application loads, the username and password for Last.fm will be prompted. See Figure 56. If the users haven't registered a Last.fm account yet, press "Sign up for a Last.fm account" then the web browser will open and direct to <https://www.last.fm/join> for registration. Fill in Username and Password after registration then press "Login".

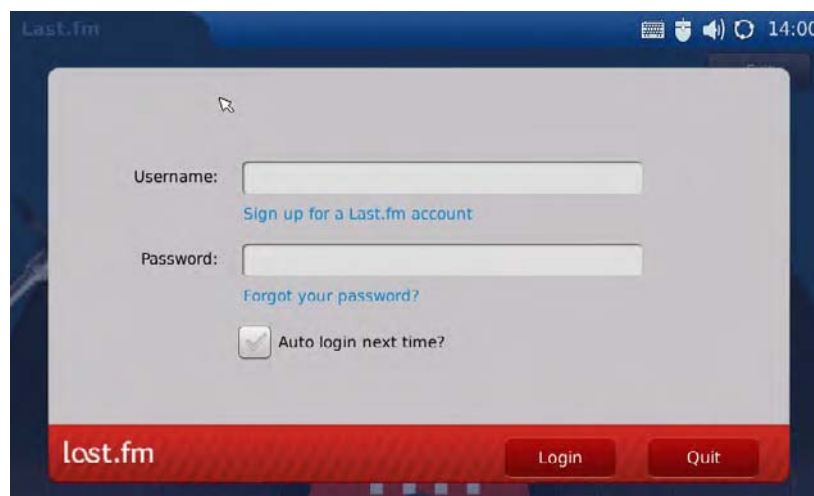


Figure 56: Last.fm->Login

If the users forget the password, press “Forgot your password”. Then the web browser will open and direct users to last.fm website to retrieve the lost password. If “Auto login next time” is selected, the users will be automatically signed in after opening Last.fm application next time.



Figure 57: Last.fm->Search music








After logging in, users could search the music by “Artist” or “Tab” by entering the name in the blank field above the playlist on the left. Press  to play the music in search result as shown in Figure 58. Users could select audio output among “Speaker”, “Headset” or “Stereo” by pressing “Output” button.



Figure 58: Last.fm->Play music

In Figure 58, users could press  to play the song and press  changing to the next song. Tap on the volume bar to adjust the volume. To add the song in “My Love Tracks”, press  then the song

will be added the list under “My Love Tracks”. If  is selected, the song will not be played again. Users could also press  to add the song in playlist. To know more about the song being played, press  to access more related information.

By pressing the small red arrow on the left, users could expand/hide the playlist. Press “Exit” button to logout Last.fm application.

VIDEO

- YOUTUBE

Online video streaming is available on the GXV3175 via integration with YouTube. Access Youtube application through “MENU”-> “Multimedia” -> “Youtube”.

All YouTube videos are viewable. There are some default video feeds for users to browse, which includes Standard Feeds (Top Rated, Most Popular and etc), Category (Music, Sports, Entertainment, News and etc), Shows, Movies and etc. (See Figure 59) Press the thumbnail and select “Watch now” to watch the video in Media Player.

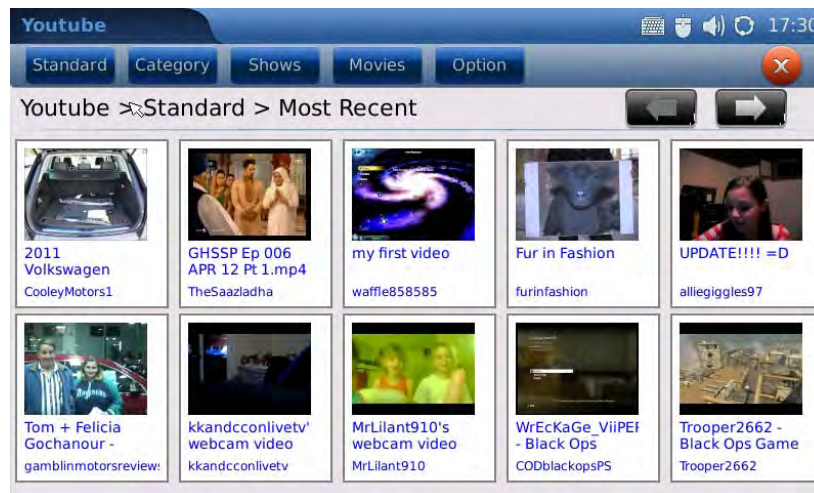


Figure 59: Youtube Application

Users can also upload their own videos to YouTube via GXV3175. To upload a video to You Tube, the user has to login with an existing YouTube account or register for a YouTube account first via Options->Login. See Figure 60.

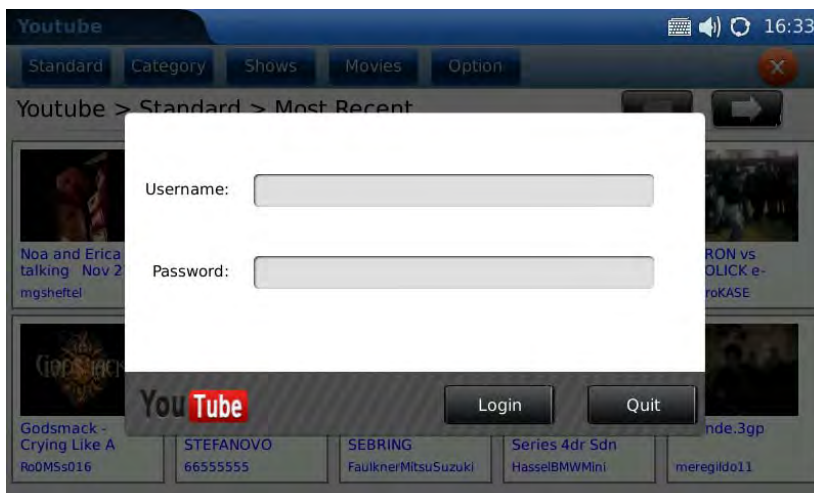


Figure 60: Youtube Account Login

After login is successful, select “Option”-> “Upload”. In the screen as Figure 61 shows, fill in the required information (Title, Category, Keyword and Description), select the video file from local or external storage device and press “Submit”.



Figure 61: Upload Videos to Youtube Account

Besides viewing videos from the built-in video feed, users can also search for videos according to keyword and preferences. This is done by pressing “Option”->“Search”. Then enter the keyword in “Search Word” and press “Search” button. (See Figure 62)

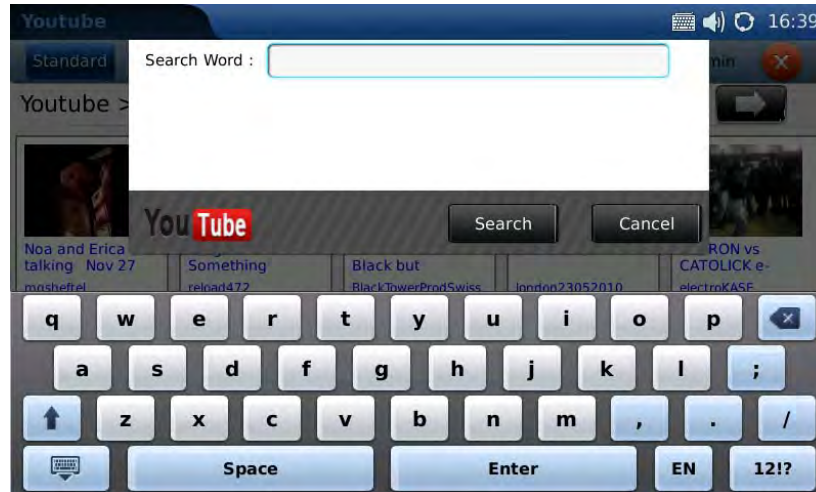


Figure 62: Search Online Videos

To add the video to “Favorite”, users need to login Youtube account. Then after select a video, press “Favorite” button (See Figure 63). Now users will be able to access to all videos marked as “Favorite” in “Option”->Favorite.

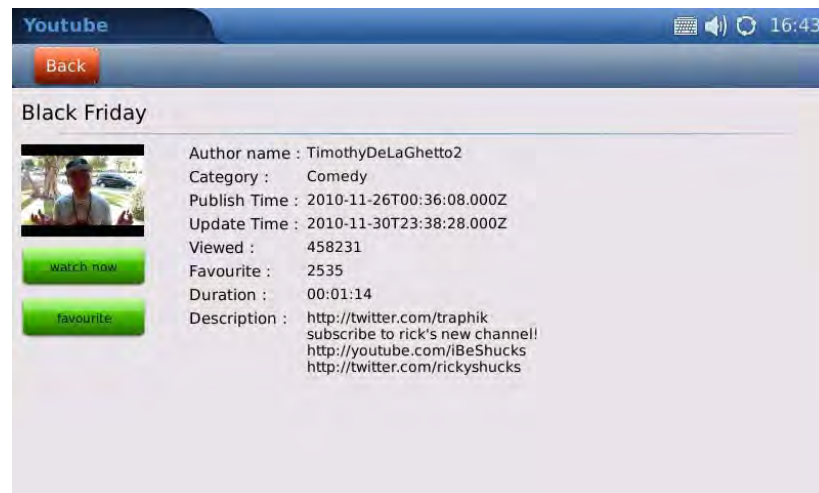


Figure 63: Add video to Favorite

- **MEDIA PLAYER**











The GXV3175's Media Player allows users to play music and video files. File formats supported are: MP3, ogg, wav, wma, avi, flv (h263/h264/vp6), mp4 and 3gp. To access the Media Player, select MENU->VIDEO-> Media Player.

To play a selected music from local or external storage device, select Options->Open File or Add File

to List. Users could choose speaker, headset or stereo in Options-> Output. After adding files to the playlist, press “Loop” to select the play mode in “Single Loop”, “List Loop” or “Loop None”.



Figure 64: Media Player->Play Music

Icon	Function
	Skip to play the next item in playlist
	Play
	Skip to play the previous item in playlist
	Pause/Stop
	Volume. Scroll the volume bar to adjust the volume.
	Delete the item in playlist
	Scroll to the previous item in playlist
	Scroll to the next item in playlist
	Options: Add File to List, Open File, Open Folder, Output, Clear List
	Loop: Single Loop, List Loop, Loop None

If users select a video to play, the video will show in the screen in Figure 65. It might take a while for loading the video. The following table shows the icons for the operation when playing the video.

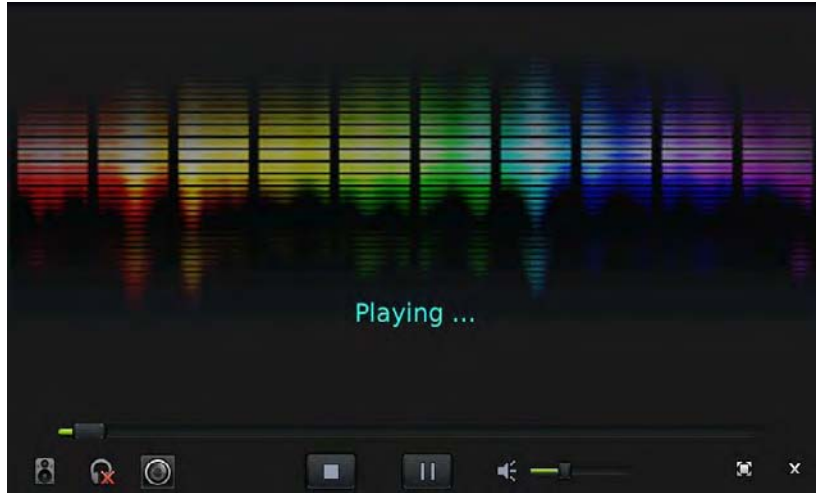










Figure 65: Media Player->Play Video

Icon	Function
	Output option: Stereo
	Output option: Headset. It will be available if the headset is plugged in.
	Output option: Speaker
	Stop
	Pause
	Full screen display
	Exit
	Volume. Press to mute/unmute. Or scroll the volume bar to adjust volume

- **MOVIE TRAILER**

The GXV3175's Movie Trailer enables users to access the latest movie information by watching the trailers. Select MENU->VIDEO->Movie Trailer then the screen will show five pages of the most recently movies in thumbnail. There are three built-in categories of movies: Just Added, Most Popular and Genre (Action, Comedy, Documentary, Drama, Family, Fantasy, Horror and etc.) See Figure 66.

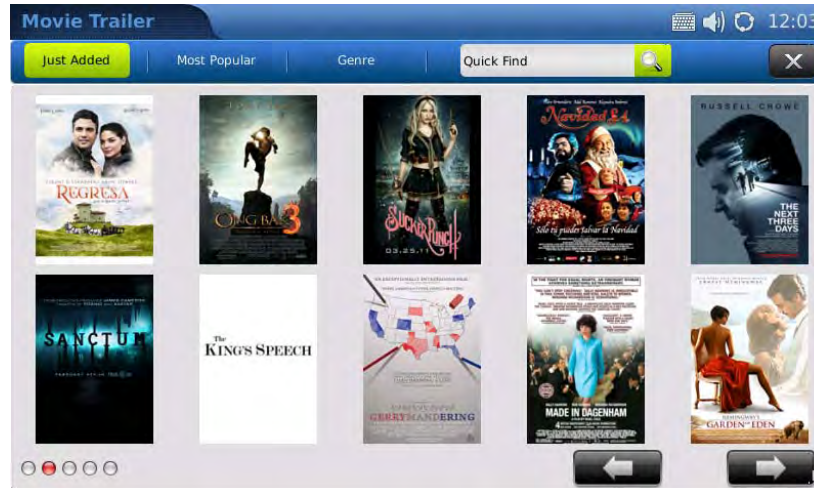




Figure 66: Movie Trailer

Press  and  to view the movies in previous and next pages which is indicated in the red dot on the left. Tap on the image of the movie to select it. See Figure 67. Press the “Down” arrow next to “watch now” button to select the trailer available to watch.

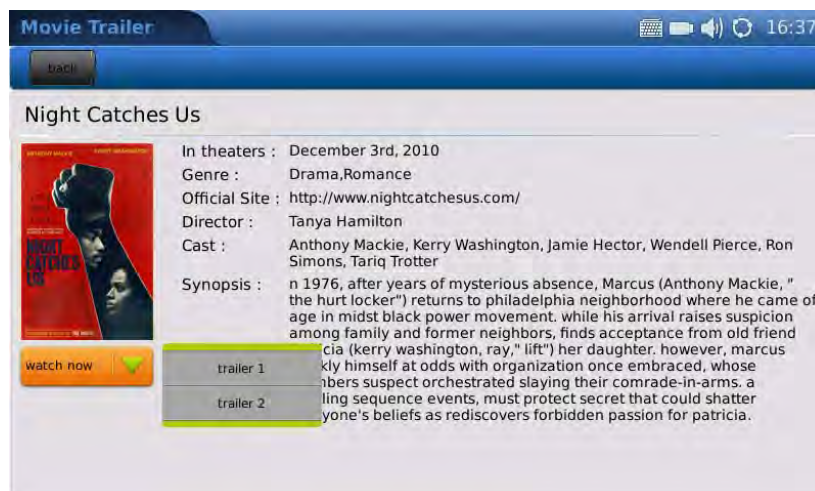


Figure 67: Select to watch a trailer

To find a movie trailer, tap on “Quick Find” and enter the name of the movie in the popping out soft keyboard. Press “Enter” in the keyboard for the searching result. See Figure 68 and Figure 69.

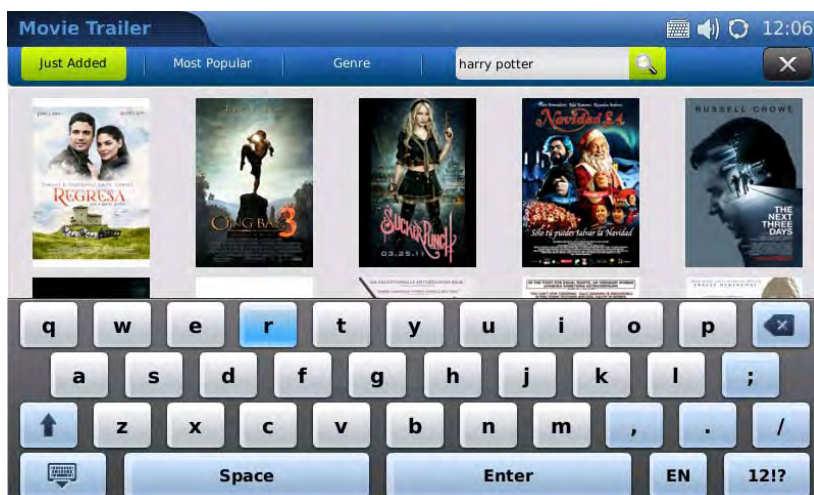


Figure 68: Quick Find in Movie Trailer

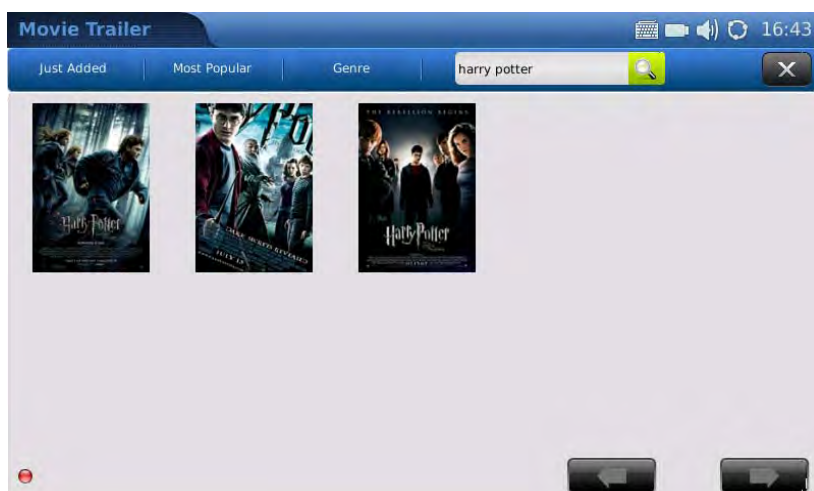


Figure 69: Searched Result in Movie Trailer

PHOTO

- PHOTO ALBUM

GXV3175 supports three popular web photo album applications: Flickr, Photobucket and Phanfare. Users can upload, view, or search for photos from online photo albums. This provides convenience as users are able to upload and share photos with relatives/friends worldwide. These three applications are accessible by selecting “MENU”->”Photos”.

Users must have an existing account with the online photo album or must register for an account with the photo album service providers (i.e. Photobucket, Flickr, Phanfare). After the application is loaded,

users will need to add the pre-exist account to login. A screen similar to Figure 70 will appear. Press “Add” then users will be directed to the web login page.

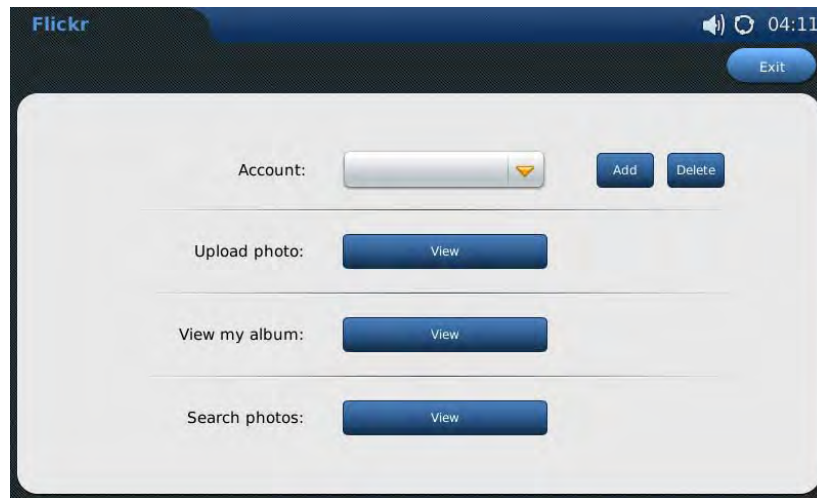


Figure 70: Flickr->Add Account

Enter the username and password and follow the instructions for authorization. After successful authorization, users could close the web browser. In “Account” (Figure 70), the account name will show there and now users will be able to upload local photos, view online albums or search for photos.

- **WORLD PHOTO**

The World Photos application gives users the ability to view thousands of beautiful photos from countries all over the world. To access this application, select “MENU”-> “Photos”-> “World Photo”. Photos are divided into categories by geographical locations, making it easy for users to locate and navigate. (See Figure 71)

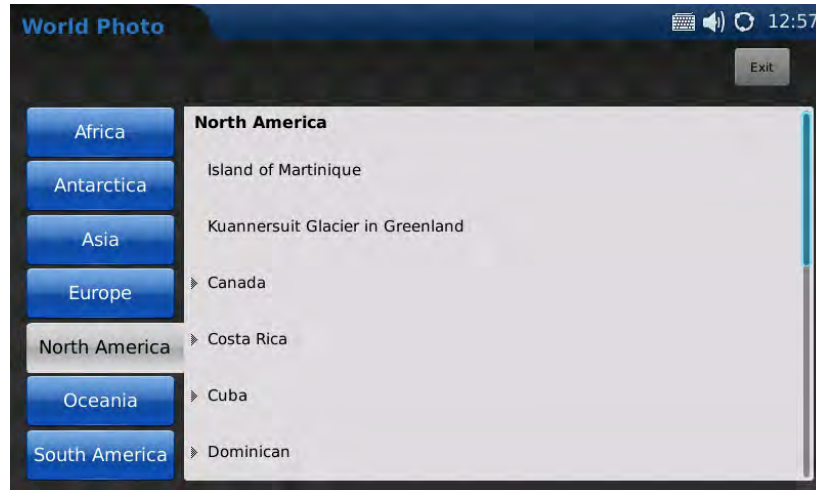


Figure 71: World Photo


Once a country of interest is selected, press the name of it the pictures will be shown in the screen. See Figure 72. Press  to next page and scroll up/down for all the available photos. To view the photo in Photo View, users could press the thumbnail and then zoom/rotate/flip the photo. Please refer to next section for more details about viewing photos in Photo Viewer.



Figure 72: View Photos from World Photos

- **PHOTO VIEWER**

The GXV3175 features a Photo Viewer which allows users to conveniently view their photos. Supported file formats are: png, jpeg, and gif.

The application is accessible through Menu->Photos->Photo Viewer. After the application loads, the

user may select to view pictures from different folders, including the files from external USB flash drive. (See Figure 73)



Figure 73: Open Folder in Photo Viewer

Tap on the folder to open it and select the photos in the folder then the screen will look similar to the Figure 74. For example, open the first picture from the “screensaver” folder.

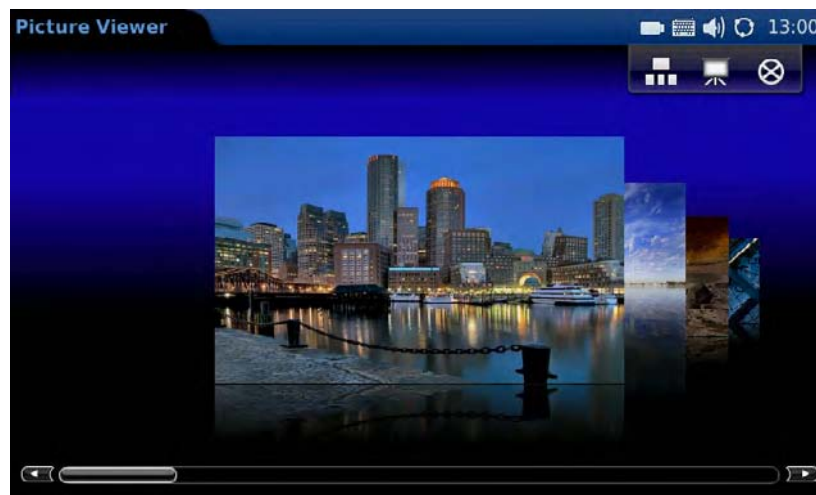


Figure 74: Viewing an image in Photo Viewer
















Users could scroll the slide bar on the bottom to view the previous/next photo. To view the photo in full screen, press  and the screen will show as Figure 75.



Figure 75: Viewing an image in Photo Viewer

In Figure 75, users could Zoom (in, out), Rotate (clockwise, counter clockwise), Flip (vertical flip, horizontal flip) the picture as well as display the pictures in a slideshow. If a picture slideshow is selected, the photos will be shown in a picture slideshow with the time frame (10/15/20 seconds) configured.

Icon	Function
	View the previous photo
	View the next photo
	View the photo in full screen
	View the photo in slideshow
	Exit
	View the photo in regular mode
	Zoom in
	Zoom out
	Expand to fit the screen
	Expand to fit the screen
	Horizontal flip
	Vertical flip
	Rotate in clockwise direction
	Rotate in counter clockwise direction

- **SLIDE SHOW**

The Slide Show application allows the user to select a set of photos and display these photos in a picture slideshow. Access this application by selecting “MENU”-> “Photos”-> “Slide Show”. The source folder for the photos includes: Customized folder, HTTP URL, World Photos, Flickr, Phanfare and Photobucket. (See Figure 76)



Figure 76: Slide Show Settings

If “Customized Folder” is selected in Source, users will need to specify the folder by pressing “Browser” to select a folder from local or external storage device.

If “HTTP URL” is selected, users will need to specify the URL. If “Flickr” or “Phanfare” or “Photobucket” is selected, the corresponding account name will show for the user to display the pictures in their online album.

Users could choose the time for slideshow display interval by entering a value for “Interval(s)”. While the picture slideshow is playing, users can also simultaneously play music from a music file or the Internet radio for background music. This Slide Show application provides the user with a sophisticated photo slideshow.

NEWS

- **NEWS VIDEOS**

In News Videos, the users are provided selections from US, World, Sci-Tech, Entertainment, Health and etc in different sites (CNN, FoxNews, BBC and etc) for the latest news and videos. Access News Videos via Menu->News->News Videos. (See Figure 77) Press Up/Down arrow to view the news/videos and then select it for the complete content.

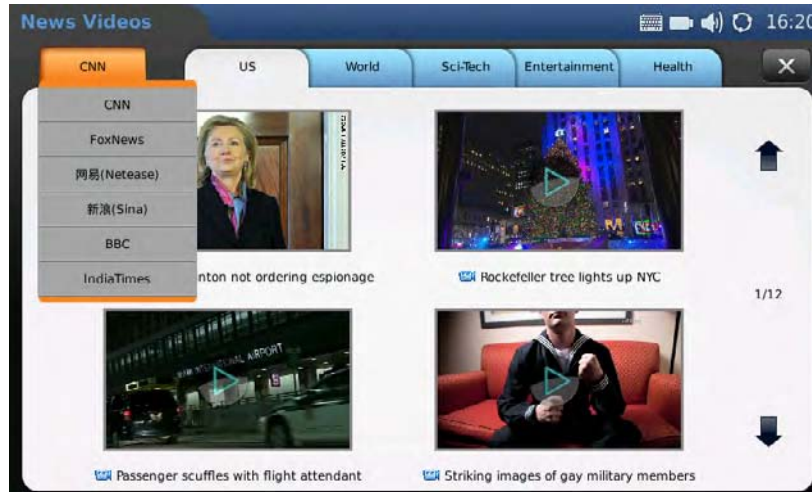


Figure 77: News Videos

TOOLS

The GXV3175 provides a collection of useful applications that are accessible via MENU including File Manager, Alarm Clock, Calendar, IP2Location and Calculator.

- **FILE MANAGER**

File manager is a tool that helps to manage files such as music, pictures and documents. Users can manage these documents efficiently through the File Manager by selecting “MENU”-> “Tools”->“File Manager”.

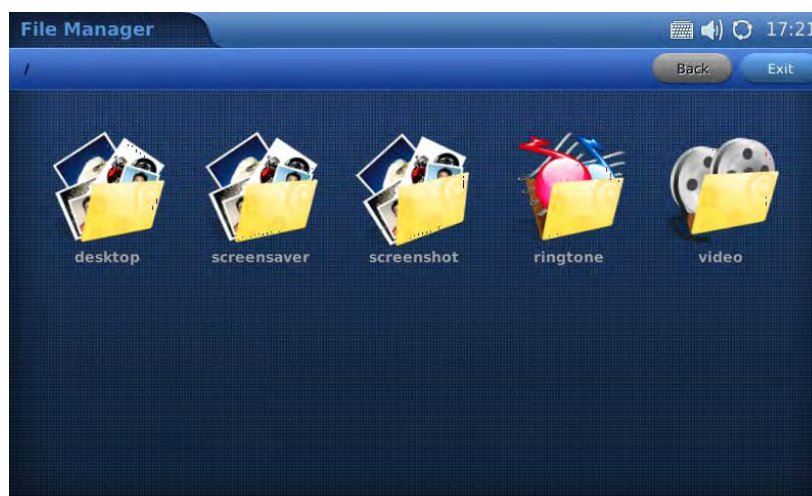


Figure 78: File Manager

In Figure 78, users can access different folders to manage their files. By default, there are five folders: desktop, savesaver, screenshot, ringtone and videos. If a USB device is connected, it will also be

displayed and accessible in File Manager.

To open the file (for example, a picture or mp3 file) after accessing the folder, users could tap on the thumbnail of the file after opening the folders.

Users could also press and hold (for 2-4 seconds) on the bottom right corner of the thumbnail to have more options to edit the file, which includes “open”, “cut”, “copy”, “rename” and “delete”.

To paste the copied file, users could press and hold (for 2-4 seconds) on the blank area inside a folder. Then two options will show up: “New directory” and “Paste”. Select “Paste” to place the file inside the folder. Or users can also create new directory by selecting “New directory”.



- **ALARM CLOCK**

The GXV3175 provides a flexible alarm clock application that lets users configure a custom alarm tone and alarm time in detail to suit their needs. Access the settings for Alarm Clock via “Menu”-> “Tools”-> “Alarm Clock”. (See Figure 79)



Figure 79: Alarm Clock Application

Three alarm clocks are available in GXV3175, each with the exact same settings options. To set the alarm, select “Yes” in “Alarm Enable”. Users could set “Snooze Time Out” to “None” or from “5 Minutes” to “30 Minutes”. The “Alarm Tone” could be set as built-in ringtones or customized by pressing “Browse” to select a mp3 file from local or external storage device.

To adjust the alarm tone volume, press  to turn down the volume or press  to turn up. The corresponding volume will show in the volume bar.

To set the recurring day, users need to tap on check box in the left hand side of the day to check/uncheck the option. After checking it, the icon will become activated as from grey.

- CALENDAR

The Calendar application is accessed by selecting “MENU”-> “Tools”-> “Calendar”. Users can view the calendar, add events to the calendar and synchronize it to a pre-existed Google calendar account. See Figure 80.

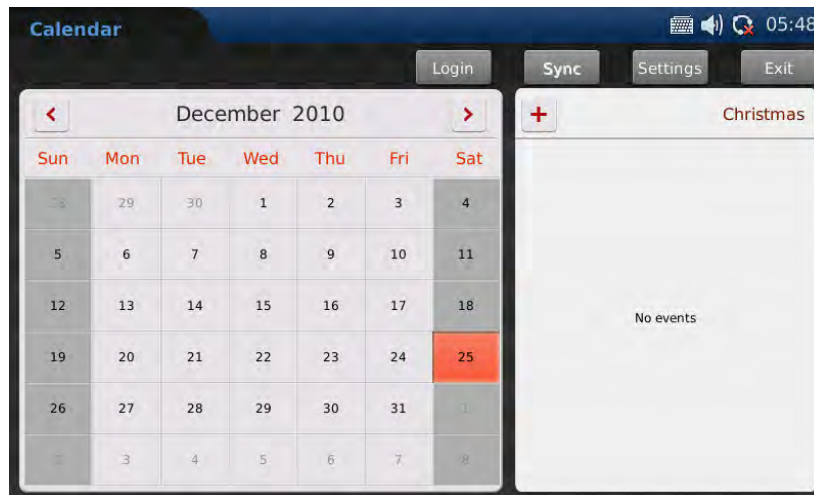


Figure 80: Calendar Application

In Figure 80, press and to move and select the month and year. Then after tapping on a date in the calendar, it will turn red with the holiday and event information (if configured) displayed in the window on the right of the screen.

To add a new event, user can press button on the right window after tapping on the day in the calendar to add new event to the selected date. Then enter the event detail in the screen shown in Figure 81. Fill in the information in “What”, “Where” and “Description” then select the event time. If the check box of “All day” option is unchecked, there will be time option for the users to set the specific time of the day. In “Repeats”, users could select no repeat, daily, weekly or monthly to set alarm alert of the event for reminder purpose. Figure 82 shows the calendar after an event is added.

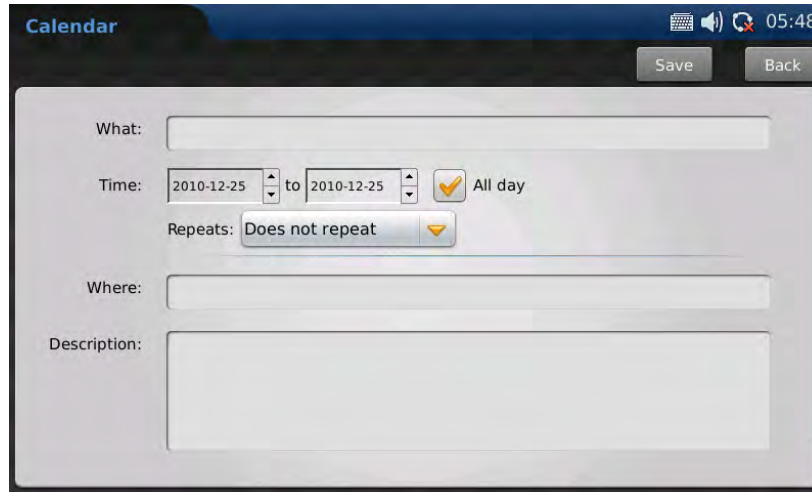


Figure 81: Add Event in Calendar

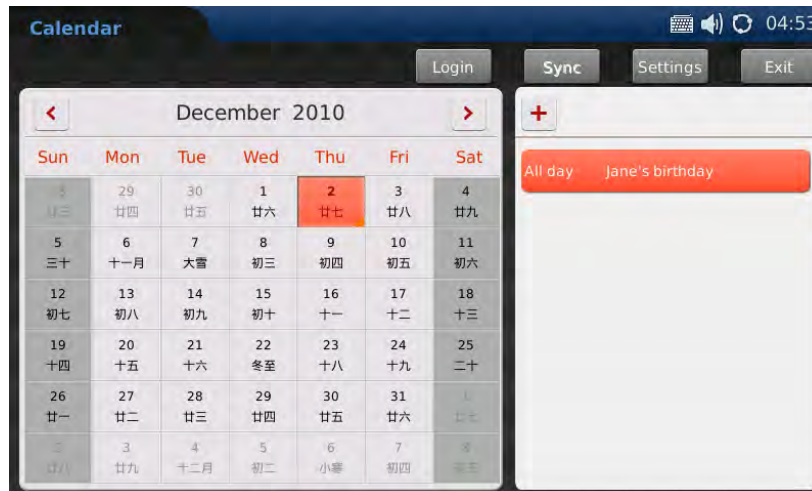


Figure 82: Event Added in Calendar

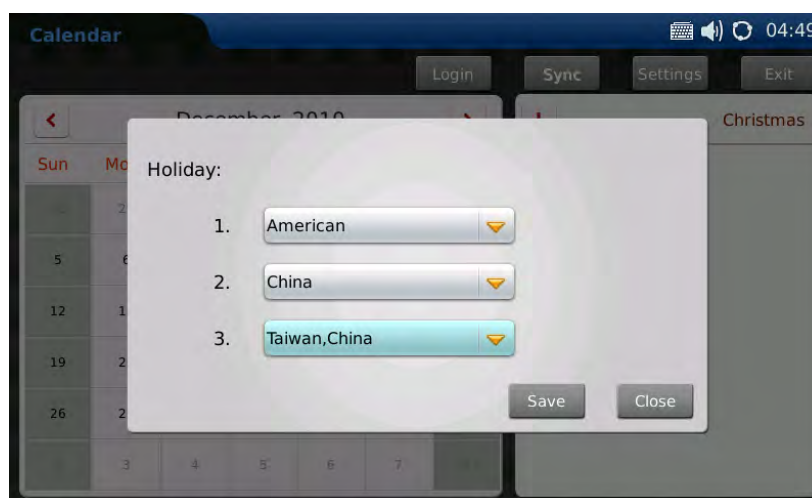


Figure 83: Holiday Settings in Calendar

To enable to feature to display holidays for different countries (as shown in Figure 82, Chinese Lunar Calendar is displayed under the date), press “Settings” and select countries from the dropdown list. The GXV3175 gives users the ability to display holidays for up to three different countries. Press “Save” after the setting. See Figure 83.

The GXV3175 can synchronize events with Google Calendar, and send out alerts for those events marked on Google Calendar. To setup Google Calendar synchronization, press “Login” on the top of the screen. Then the Email and Password associated with the Google Calendar will be prompt. Enter the account information and press “Login” button in Figure 84.

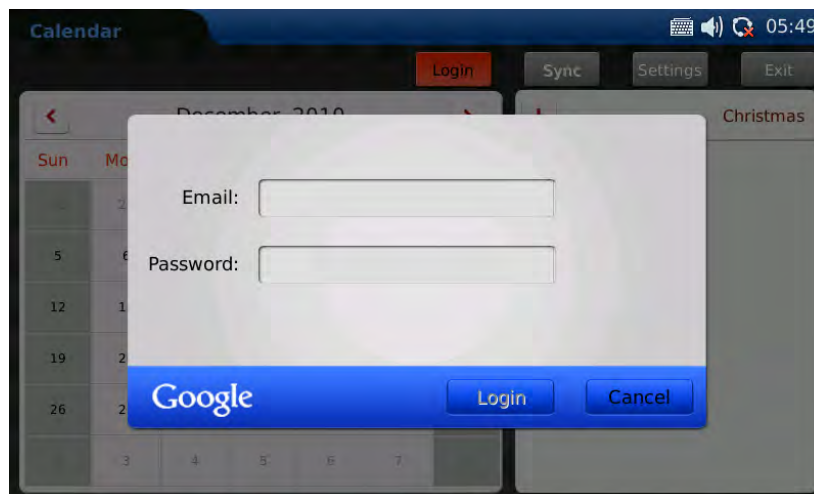


Figure 84: Synchronize with Google Calendar

After logging in and setting with Google Calendar account, press “Sync” on the top of the screen to finish the synchronization.

- **IP2LOCATION**

The IP2Location Application provides users with a tool to resolve the IP address to the location. It is accessible through “MENU”-> “Tools”-> “IP2Location”. To begin, tap on the blank field for “IP Address” and enter the IP address using the popped-out soft keyboard. Press “Search” button to view the resolving result. See Figure 85.



Figure 85: IP2Location Application

Based on the IP address provided, the following information is given: Country, Region, City, Latitude, Longitude, Time Zone and Weather Code. This information is useful when configuring the phone to provide personalized settings based on the users' location.

- **CALCULATOR**

The GXV3175 also includes a Calculator which is accessible by selecting MENU->Tools-> Calculator. To operate the calculator, press the corresponding number on the keypad. The arithmetic operations (e.g. add, subtract, multiply, divide) are defined by the corresponding arrow buttons.

There are three categories of calculators available in the application. Press "Simple", "Science" or "Finance" to select the calculator based on the users' requirement. Please refer to Figure 86, Figure 87, and Figure 88 for these three built-in calculators.



Figure 86: Calculator: Simple

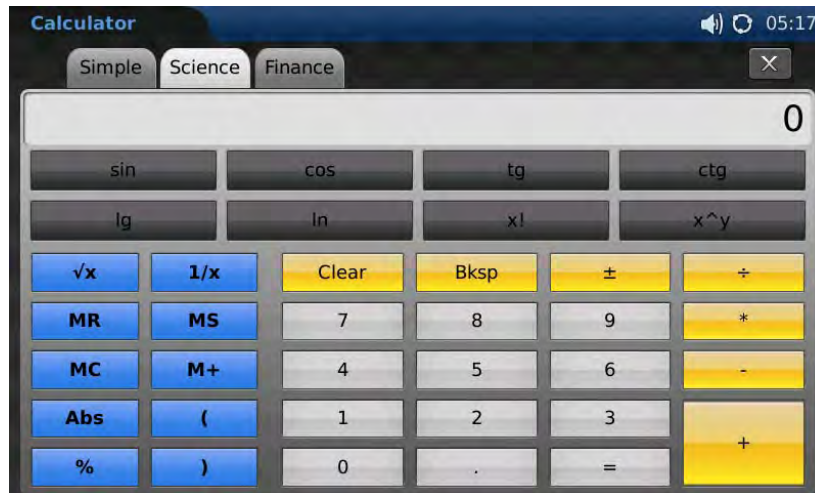


Figure 87: Calculator: Science

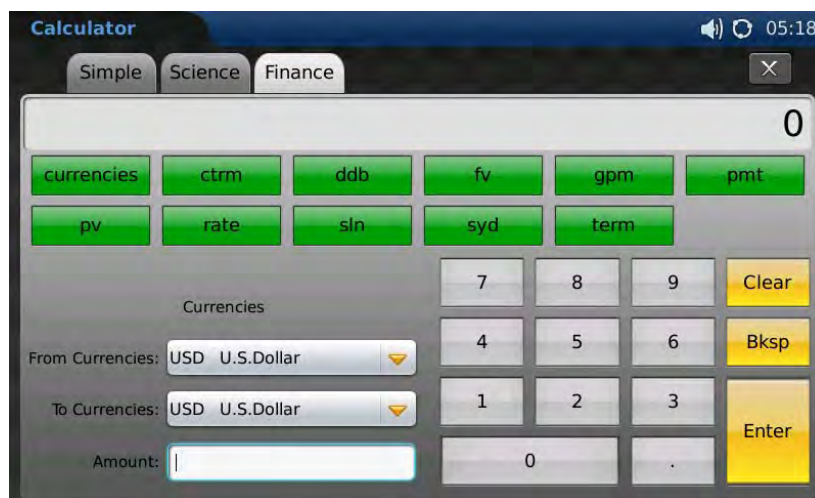


Figure 88: Calculator: Finance

SYSTEM SETTINGS

The System Settings allows users to configure settings for Accounts, Network, Time, Display, Maintenance, Camera, Video, Call Features, Screen Saver, Background, Tones and Language. Press MENU->System Settings and select the corresponding icon to access the settings. See Figure 89.



Figure 89: System Settings

- **ACCOUNT SETTINGS**

Account Settings allows users to configure the three SIP accounts; the same configurations may be completed by accessing the web configuration interface. Users may need to provide SIP account name, SIP server URL, authentication information and proxy information to set up account successfully. Press “Save” button after the account setting. See Figure 90.



The screenshot shows the 'Accounts' settings window with three tabs: 'Account 1', 'Account 2', and 'Account 3'. The 'Account 1' tab is active. The form contains the following fields:

- Account Name: IPVideoTalk
- SIP Server: sip.ipvideotalk.com:48879
- Outbound Proxy: (empty)
- SIP User ID: 8100034
- SIP Auth ID: 8100034
- SIP Auth Password: (masked with dots)
- Display Name: (empty)

Buttons for 'Save' and 'Exit' are visible in the top right corner.

Figure 90: Accounts Settings

- NETWORK SETTINGS

GXV3175 supports various network connections including Wifi and proxy. Users can access all the network setting via Menu->System Settings->Network Settings. Four tabs will show as can be seen in Figure 91: Connection, Other, Wifi and Proxy.



The screenshot shows the 'Network' settings window with four tabs: 'Connection', 'Other', 'Wifi', and 'Proxy'. The 'Connection' tab is active. At the top, there are three radio buttons for connection type: DHCP (selected), PPPoE, and Static IP. Below are the following fields:

- PPPoE Account ID: (empty)
- PPPoE Password: (empty)
- IP Address: 67.110.250.183
- Subnet Mask: 255.255.255.192
- Gateway: 4.2.2.1
- DNS Server1: 4.2.2.2
- DNS Server2: 0.0.0.0

Buttons for 'Save' and 'Exit' are visible in the top right corner.

Figure 91: Network Settings: Connection

In page “Connection” (See Figure 91), users can choose to use DHCP, PPPoE or Static IP. If PPPoE or Static IP is selected, users will be required to enter the corresponding account information or configurations.

In page “Other”, users may choose to set the Preferred DNS server, Layer 3 QoS, Layer 2 QoS 802.1Q/VLAN tag and Layer 2 QoS 802.1 priority value. (See Figure 92)



Figure 92: Network Settings: Other

The GXV3175 supports three wireless modes: 802.11b/g/n. By default, the Wifi function on the phone is disabled. Users can configure the wireless settings by selecting “Enable” in “Wifi Function”. See Figure 93.



Figure 93: Network Settings: Wifi

Before using the Wifi, users need to add the ESSID within the range by pressing “Configure...” button. This would bring up a Wifi ESSID configuration page (See Figure 94) Press “Scan” to search for the available ESSID within the range and a list of search result will display with the signal quality. If the ESSID is not shown in the searching result, the users could add it manually using the “Add” function on the bottom after entering the ESSID by tapping on the blank field.

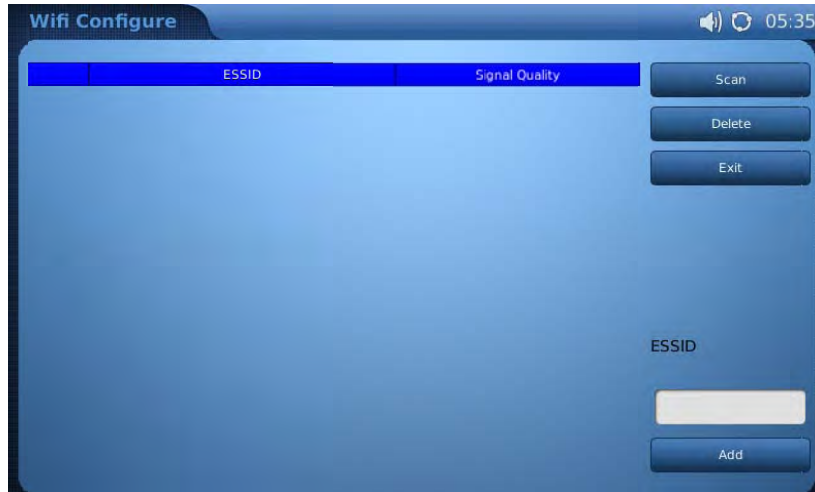



Figure 94: Scan or Configure Wifi ESSID

After the user selects the ESSID, return to the Wifi menu to configure the wireless network security mode and key. See Figure 95. The supported Security Mode in GXV3175 includes “WEP/Open”, “WEP/Shared”, “WPA PSK TKIP”, “WPA PSK AES”, “WPA2 PSK TKIP” and “WPA2 AES”.



Figure 95: Security Mode and Key in Wifi Configuration

After the users save the settings, the phone should be able to connect to the Wifi network if the authentication credentials are correct. The Wifi network strength icon  will be displayed on the LCD. The users can access the MENU->System Info->Network on the phone to view the current IP address and other network status.

NOTE: If the user has the connection to the Internet through both the wired network and the Wifi Network, the phone will use the wired network as it is have a higher priority.

The GXV3175 also supports HTTP/HTTPS/FTP proxy for the applications. If the proxy server is specified, the phone will send the packets to the proxy server which will act as an intermediary to route the packets to the destination. (See Figure 96) The HTTP/HTTPS/FTP proxy field defines the URL of the proxy server and the protocol to be used. The field “No proxy” defines the destination IP address where no proxy server is needed. The phone will not use a proxy server when sending packets to the destination IP address specified.

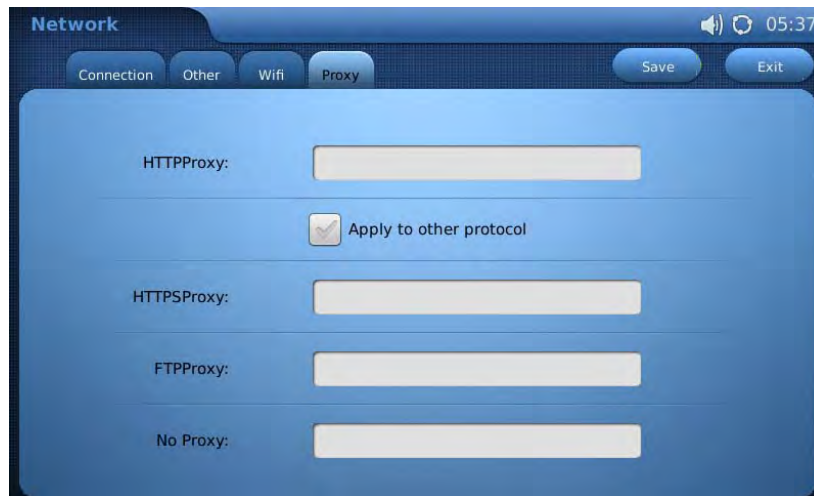


Figure 96: Network Settings: Proxy

- TIME SETTINGS

The GXV3175 allows the time to be updated automatically through an NTP Server. Users must define the Time Zone or use a Self-defined Time Zone. The display format for the time and date can also be specified by accessing the application and selecting “MENU”->”System Settings”->”Time”.



Figure 97: Time Settings

See Figure 97, in Manual (YY-MM-DD), users could tap on the blank field and edit the time then press “Apply”. Press “Save” button after finishing the settings. Then the time will display at the right corner of the top status bar in the LCD screen as configured.

- **DISPLAY**

Users can adjust the LCD Backlight brightness in display settings. By tapping the left/right hand side of the cursor on the brightness bar, users could turn down/up the brightness strength from 1 to 10 (Default value). Press “Save” after configuration. See Figure 98.



Figure 98: Display Settings

Users could mount the phone’s screen on TV via the settings in display as well. Please make sure to plug in the external output source before selecting this option.

After the external output source is set and connected, press the “Down” arrow in “TV Out” option and select “Enable”. Then press OK. Now the phone’s LCD will black out and the screen will show up in TV.

To return the display to the LCD menu, log into the web browser interface and disable TV Out in “Device Manager” -> “TV Output”. Otherwise, the phone will need to reboot to enable the LCD screen.

NOTE: It is recommended to plug in the mouse via USB port when using TV Out, which will make the operation on the touchscreen easier.

- MAINTENANCE

There are four tabs for users' selection on the Maintenance setting screen under MENU->System Settings->Maintenance: Upgrade, Factory Functions, Debug and Backup.

In page "Upgrade" (See Figure 99), users could select the upgrade mode (TFTP, HTTP or HTTPS), configure the firmware server IP address/URL and System Config Server IP address/URL. Once this is saved, users can choose to reboot the phone by pressing "Reboot" button to upgrade the firmware.

To do a factory reset, users could press the "Down" arrow in "Factory Reset" options and select the reset mode to "Full Reset", "VoIP Data Reset" or "User Data Reset". After the selection, press "Reset" and select "Yes" in the alert message "Do you want to reboot to recover factory reset". Then the phone will reboot recovered to factory default settings. A more detailed step-by-step guide will be given in the "Restore to Factory Default Settings" section that follows.



Figure 99: Maintenance->Upgrade

NOTE: After factory reset, a calibration operation is required before the phone's main screen shows up. Please follow the instructions on the screen to finish calibration before using the phone.

In page "Factory Functions", GXV3175 provides some testing diagnostics for the LCD, camera and video, audio and touchscreen on the device. Press "Start" and follow the instructions on the screen for each test. (See Figure 100)

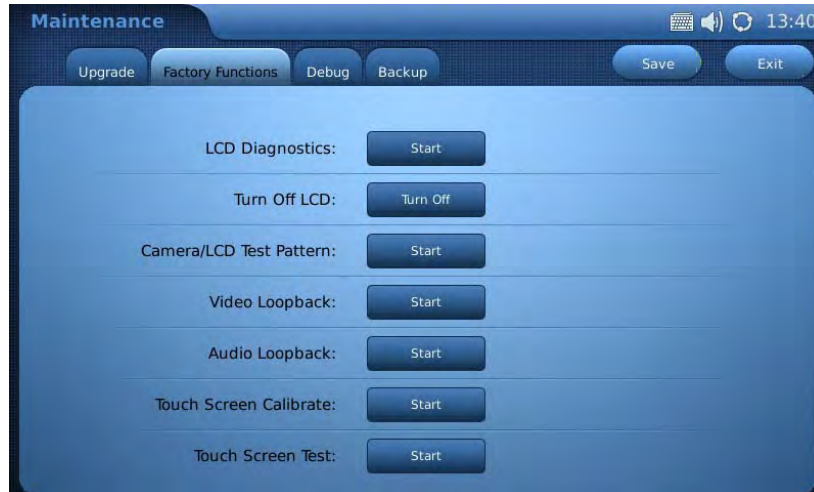


Figure 100: Maintenance->Factory Functions

The Debug page (as shown in the Figure 101) contains the built-in debug tools for the GXV3175. The debug tools make it more convenient to obtain corresponding information and traces when the system encounters problems. To start capturing traces, users need to Enable Application Debug and press the “Start” button next to the Capture Packets option. The captured traces are available for downloading through the web configuration interface and can be sent to Grandstream Support for troubleshooting.



Figure 101: Maintenance->Debug

To perform a network connection test, users could enter the IP address in “Network Test (Ping)” to ping the destination. The testing result will show in the table below in Figure 101. Press “Stop” to stop the operation.

In page “Backup” (See Figure 102), Backup/Restore functionality is provided to the users, making it

easy to backup any current configuration settings on a regular interval (daily/weekly/monthly) and restore these settings on the phone if needed.

Tap on the “Down” arrow to choose the backup/restore interval. Then select the data to be uploaded by checking the box of the corresponding items in “Data Includes” option. Users can choose to upload the data to a default server or a user-defined TFTP server.

Press “Upload now” or “Restore now” to activate the operation immediately. The file uploaded will be a file associated with the MAC address of the phone.



Figure 102: Maintenance->Backup

- CAMERA

This camera setting under MENU->Settings->Camera allows the user to modify the camera settings for the GXV3175. Settings such as Color Mode (Polychrome Mode, Monochrome Mode), White Balance (Auto, Fixed), Flicker Control (Auto, 50Hz, 60Hz) and Lens Correction (Disable, Enable) can be configured. (See Figure 103)



Figure 103: Camera Settings

Make the proper selection based on the users' requirement and press "Save".

- **CALL FEATURES**

The Call Features menu allows the user to configure Call Forwarding methods and other features such as Call Waiting, DND and Direct IP Call. Users can configure the three accounts to different call forwarding schemes. See Figure 104 and Figure 105.

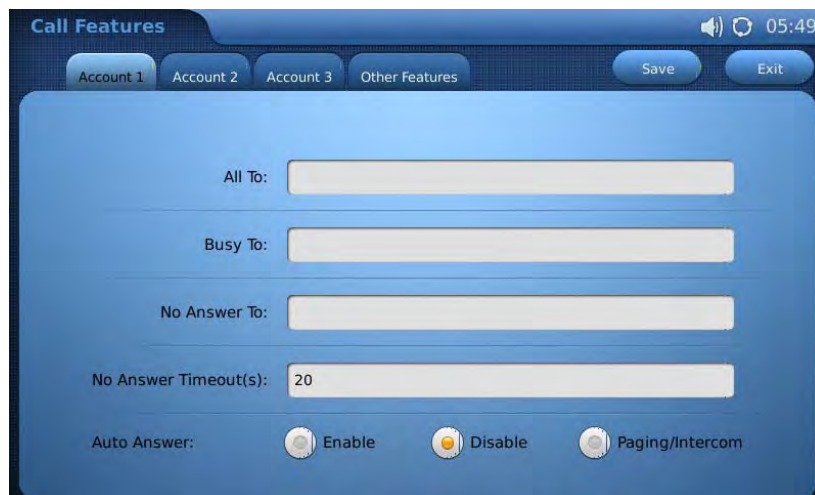


Figure 104: Call Features->Call Forwarding Settings on each account

Option	Description
All To	Call Forward unconditionally

Busy To	Call Forward when busy
No Answer To	Call Forward on no answer
No Answer Timeout(s)	Call Forward if no answer after the timeout value(s)
Auto Answer	Three options: "Disable", "Enable" and "Page/Intercom". By default it is set to "Disable"

Other features include configuration for Do Not Disturb, Call Waiting, Call Waiting Tone, and Direct IP Call could be disabled/enable as shown in Figure 105.



Figure 105: Other Call Features

After the settings are configured, select "Save" to save and activate the settings.

- VIDEO

Video Settings can be accessed by selecting MENU->System Settings->Video. It allows users to configure parameters related to the video during call, which includes Frame Rate, Packet Size, Rate Control, I-Frame reference Only, Redundant P-frame and Packetization Mode.

Normally, users do not need to change the default settings. However, if the network bandwidth allows it, users can increase the frame rate for better video quality.



Figure 106: Video Settings

- SCREEN SAVER

When the phone is in idle, the photos will be displayed as configured in Screen Saver. The default folder for the pictures used in screen saver could be accessed from Menu->Tools->File Manager->Screensaver. Users could also specify the pictures from a local/external folder by selecting “Customized Folder” in “Screen Saver” option.



Figure 107: Screen Saver Settings

See Figure 107. Users could set the Interval (s) which defines the interval for the pictures to display in screen saver mode. After setting the “Time Out (m)” value, the phone will start to display the pictures when the time out expires in idle screen. “LCD Auto Power off Time (m)” will let the phone enter the power saving mode after the time out. Press “Save” to make the settings take effect.

- **BACKGROUND**

GXV3175 has four desktops and each of these could be set to different background according to users' preference.

See Figure 108. For each desktop, users could select a Color or a image from local/external files to display. After the selection, users could preview the settings and then press "Save" for the phone to take effect.

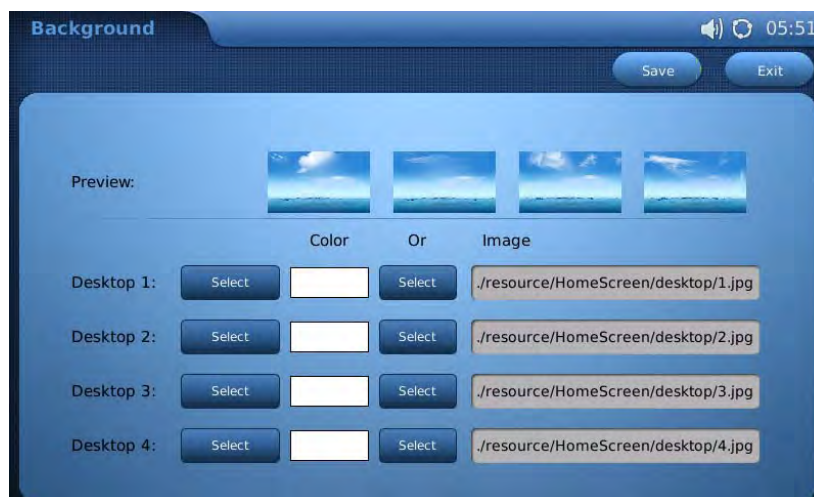


Figure 108: Screen Saver Settings

- **TONES**

The Tones Manager configures the volume, tones different ringtones for the 3 SIP accounts. The Tones menu is accessible by selecting "MENU"-> "System Settings"-> "Tones". (See Figure 89)



In page "Volume", users could press the speaker icon  or  to turn up/down the key volume and ring volume. See Figure 109.



Figure 109: Tones->Volume

In page “Tones”, users could set the Event Alert Tones for the events added in Calender application, New Message Tone and Key Tone when pressing the touchscreen. All the tones could be set from the built-in tones/music or from local/external storage file if “Customized” is selected. See Figure 110.



Figure 110: Tones Settings

In page “Ring Tones”, users could select the account then set the ringtone for the incoming call. See Figure 111. In GXV3175, two Caller IDs could be set to use distinctive ring tone for the users to identify more conveniently. Enter the Caller ID in “Match Incoming Caller ID” and select the ringtone. Then “Press” Save for the configuration to take effect.



Figure 111: Ring Tones Settings

- LANGUAGE

There are three built-in languages available in GXV3175: English, Simplified Chinese and Tradition Chinese. Tap on the “Down” arrow and make the selection in “Select Language”. Press “Save” then the phone will prompt alert message “Do you want to reboot to take effect immediately now”. Select “Yes” to reboot the phone immediately or “No” for the phone to take effect after rebooting later on. See Figure 112.



Figure 112: Language Settings

GXV3175 supports multi-languages including Spanish, German, French, Czech, Japanese, Korean, Portuguese and Italian. Users need to specify the language file and download it to the phone for these languages. Select the download mode and specify the download server, then press “Download”. The

phone will boot up with the language as configured by users' preference.

SYSTEM INFO

In MENU->System Info, users could view the status about the account, system and network. Please check the system info before troubleshooting if necessary.

Account info shows the account and registration status on the phone. See Figure 113.



Figure 113: Account Info

System info shows the product model, hardware version, part number, system up time and software version. See Figure 114.

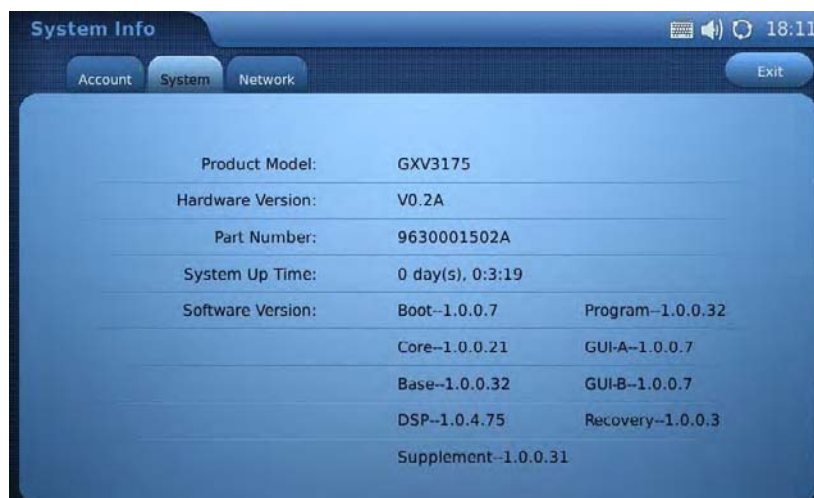


Figure 114: System Info

Network info shows the phone's MAC address, DHCP/Static IP/PPPoE, IP address, subnet mask, gateway, DNS server and NAT type. See Figure 115.



Figure 115: Network Info

PIP





In MENU->PIP, users could utilize the built-in camera in GXV3175 to take photos and record video. See Figure 116.



Figure 116 PIP Application

To take a photo, press “Snapshot” and then the photo will be saved to folder “Snapshot” in File Manager.

To record a video, press “Record” and start. Then press “Stop” after the recording. The video will be saved to folder “Video” in File Manager.

Users could view the snapshot in full screen by selecting “Full Screen”. To zoom in and zoom out, tap on  and  and scrolling bar above will show zooming status. Users could also press  and  to adjust the brightness while using the camera. Press “Exit” button to close the PIP application.

DESKTOP WIDGETS

In GXV3175’s desktop, there are four main screens. In each screen, two widgets are displayed by default:



Screen 1: World Clock, SIP Account Info


Screen 2: Weather, Currency

Screen 3: News Videos, Stock

Screen 4: Calendar, RSS News

Users could customize the desktop by closing these widgets and placing other widgets on it. .

To personalize users’ own desktop, press and hold on the existing widgets for 2-4 seconds to activate the option  and  for setting and closing respectively. When the option is activated, users will be allowed to adjust the position of the widget by holding and dragging it. It can be moved up/down/left/right in the same screen or laid on to other screens as well.

To open new widgets on the desktop, press  and the widget menu in the bottom will show including “Info”, “Weather”, “RSS News”, “Contacts (Favorite)” and “Internet Radio (Favorite)”. (See Figure 117)



Press  to hide the widget menu.



Figure 117: Desktop Widgets

The following sections describe how to configure and utilize these widgets in detail.

- **WORLD CLOCK**

In the first screen, a clock will show the current time on the desktop for users' convenience. To set up the time on the clock, activate the setting option by pressing and holding the finger on the clock. Then press .

Now the screen will show as Figure 118. Users could change the Name and Style for the clock here. The style can be previewed on the right after the style is selected.



Figure 118: World Clock Settings->Exterior

Press "Time Zone", users will see a list of options. After checking on the box for the time zone, the time on the clock will be automatically updated accordingly. See Figure 119.

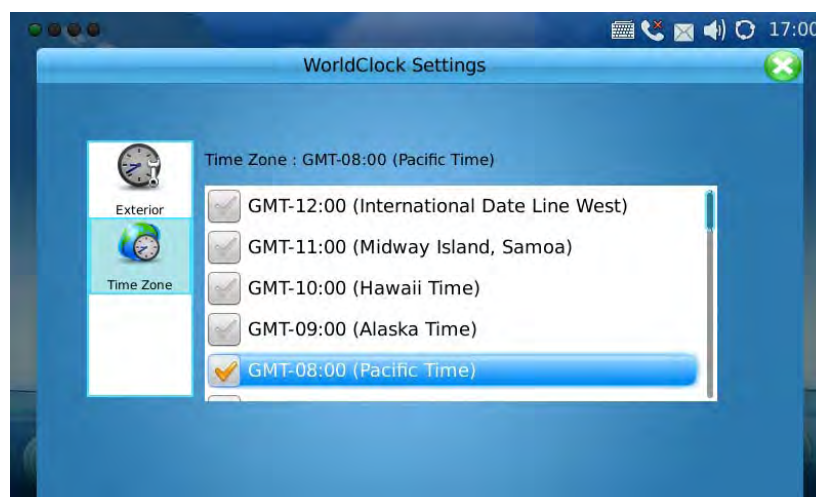



Figure 119: World Clock Settings->Time Zone

- CURRENCY

As highlighted in Figure 120, Currency application is displayed for users to access the latest conversion between different currencies. To modify the settings for currency, activate the setting option and press .

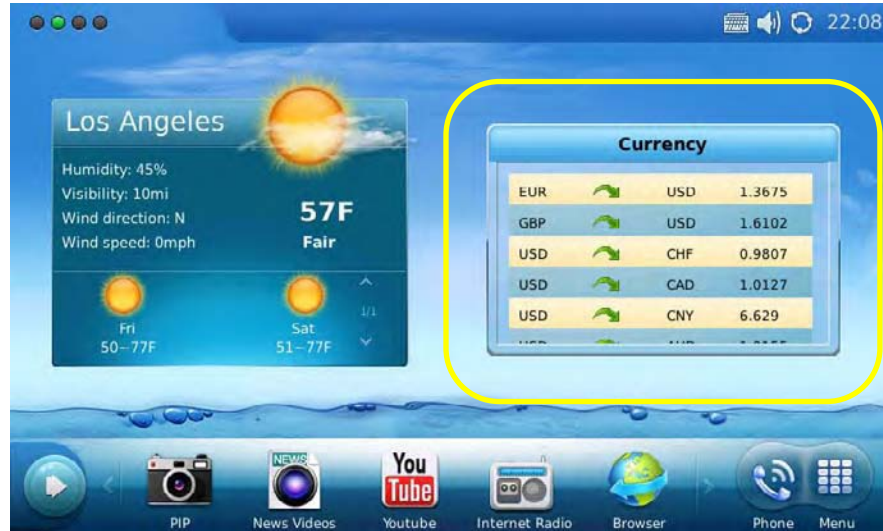


Figure 120: Desktop Widget->Currency

Figure 121 shows the Currency Settings. Enter the value in “Refresh Time (m)” to change the updated interval for the currency information,

In the currency conversion table below, select one row and press the “Delete” button then this item will be hidden. To add new currency conversion entry, in the last row of the table, select the currency to convert from and to, then press “Add” button.



Figure 121: Currency Settings

- NEWS VIDEOS

Figure 122 shows the News Videos from CNN. The thumbnail of the news and videos will be displayed in slides in the widget. To access the detail, press the thumbnail then the content of the news or the video will be available in full screen. To select news/videos from different category, press the red left/right arrow on the top of the widget.

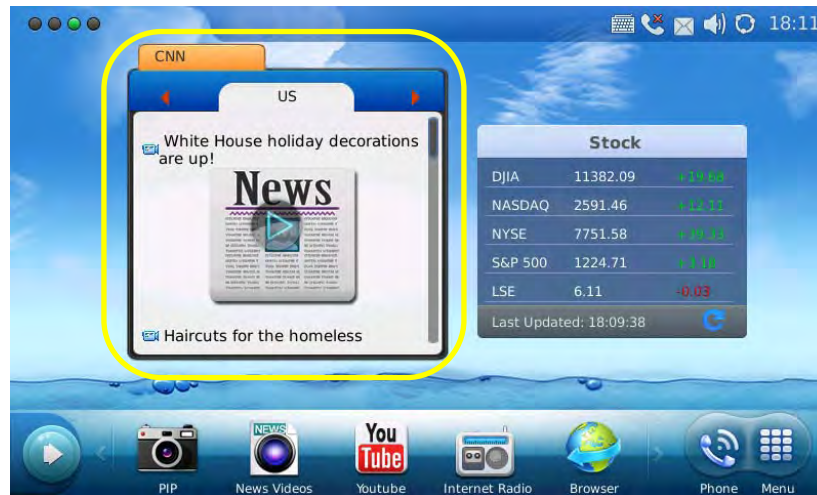



Figure 122: Desktop Widget->News Videos

Similar to other widgets, press  to access News Videos settings. See Figure 123. The slide times (s) and sites list could be set here. Also, users could disable/enable the categories by checking/unchecking box for the corresponding options.

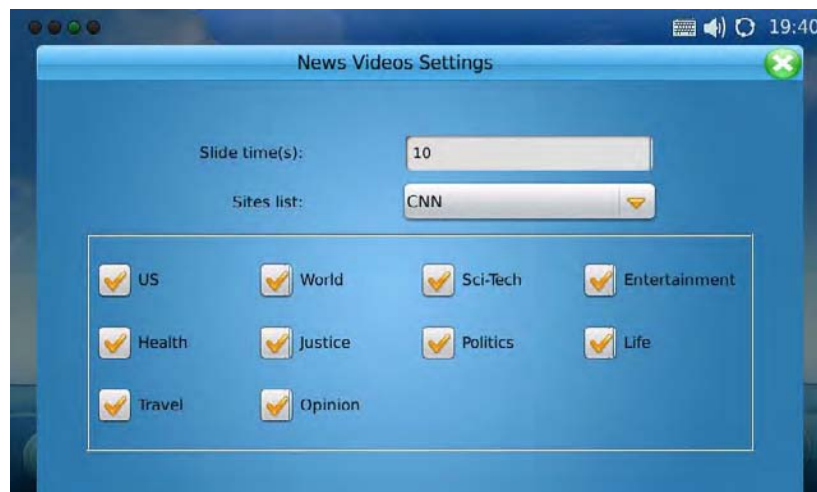


Figure 123: News Videos Settings

- STOCK

Figure 124 shows the Stock information which monitors the world stock market in real-time.

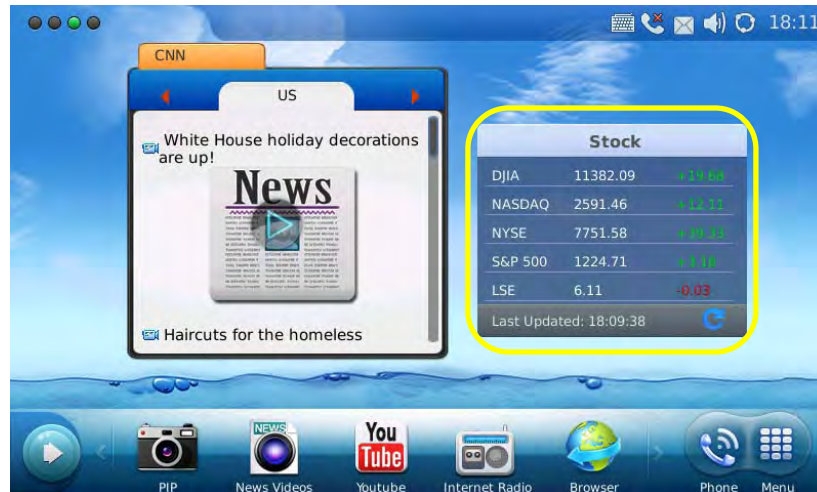


Figure 124 Desktop Widget->Stock

In the settings shown in Figure 125, users could set the refresh time (m) and color types for the current stock information.

To delete one entry, select and press “Delete” button on the right. In the last row of the table, users could also add new entries by tapping on the blank area and select “Add”.




Figure 125: Stock Settings

- WEATHER

Figure 126 shows the Weather widget in GXV3175. The weather information includes humidity, visibility (mile), wind direction, wind speed (mph) and temperature in unit as configured by the users.



Figure 126: Desktop Widget->Weather

Press  to access weather settings. See Figure 127. Enter the Update Time (m) and select Unit (Fahrenheit or Celsius) according to users' preference.

To check weather in a particular location, users need to add the city first. In Figure 127, tap on the blank area of "City Name" and enter the name via the soft keyboard. Then press "Search". Now the list of result will appear in "Search Result". Select the desired location and press "Add" button. Then the city will show in highlighted area below with the weather information in the widget on desktop.



Figure 127: Weather Settings

Users could add more than one city in weather widgets according to the demands. To delete the location, select the city in the “City” box and press “Delete” button.

- **RSS NEWS**


Figure 128 shows the RSS News widget in the desktop of the last screen. The news is kept updating with “last updated time” on the bottom line. Users could press  to refresh the page, scroll up/down to view the abstract of the news and press the news to access the complete content.



Figure 128: Desktop Widget->RSS News

In RSS News settings (See Figure 129), users could set the update time (m) for the news to be refreshed. Make selections on the options in “Subscribe” by checking on the preferred categories. To add RSS Feed, tap on the blank field of “RSS Feed” and enter the link. After pressing “Add”, it will be added in the box above.



Figure 129: RSS News Settings

To delete the feed, simply select it in the box and press “Delete” then it will not be updated in RSS News on the desktop.

- **CONTACTS (FAVORITE)**






In the screen, users could place the favorite contacts on the desktop if the contacts will be used frequently.



Figure 130: Desktop Widget->Contacts (Favorite)

Slide to left/right to select the contact in the favorite list. Then users could press or to dial out or send message.

Refer to the table below for more operations in this widget.

Button Icon	Function
	Make a call to the selected favorite contact
	Send message to the selected favorite contact
	Add new favorite from Contact list
	Remove the selected contact from favorite list
	Edit the selected contact

- **INTERNET RADIO (FAVORITE)**

If users have preferred channels in internet radio application, press in the widget menu and place “My

Favorite Radio” on the desktop for easy access.

See Figure 131. There are two methods to add favorite items via the widget.

1. In the center of the Internet Radio window, users could see the instructions and press to open internet radio application, then make selections and set favorite channels as mentioned in “Internet Radio” section.
2. Also, by pressing **+** button, users will be able to directly specify the Radio Name and Radio URL in the popped out window. Press “OK” after editing the radio information.



Figure 131: Desktop Widget->Internet Radio (Favorite)

SOFTWARE UPGRADE

The GXV3175 can be upgraded via TFTP/HTTP/HTTPS by configuring the URL/IP Address for the TFTP/HTTP/HTTPS server and selecting a download method. To configure a valid URL for TFTP or HTTP, the server name can be the FQDN or IP address format. Examples of valid URLs:

1. fw.ipvideotalk.com/gs
2. 72.172.83.110

There are two ways to setup a software upgrade server: Via Menu or the Web Configuration Interface.

UPGRADE VIA MENU

In “Menu”->“System Settings”->“Maintenance”, users could configure the software upgrade server through the menu in the phone. In the “Upgrade” subpage, users may then select the upgrade mode and enter the IP address or FQDN of the Firmware server and the System Config server. After making the changes, press save to apply the new settings and reboot the device for upgrading.

UPGRADE VIA WEB BROWSER CONFIGURATION PAGE

Open a web browser and enter the IP address for the GXV3175. Next, log in with the administrator username and password. Under Maintenance, select “Upgrade and provisioning”, enter the IP address or the FQDN (URL) of the upgrade server and choose to upgrade via TFTP or HTTP/HTTPS. Save the changes and reboot the unit.

At this moment, the LCD will display the progress of the software download/upgrade. Please do not disrupt or power down the unit.

NOTE: The software upgrade will last up to 5 minutes (through the LAN side) and may take longer when upgrading through the Internet (limited by the network bandwidth). Grandstream recommends downloading and upgrading the software in a controlled LAN environment.

NO LOCAL TFTP SERVERS

For users without a local TFTP server, Grandstream offers a NAT-friendly TFTP server. This enables users to download the latest software upgrades for their phone via this server. Please refer to the webpage: <http://www.grandstream.com/firmware.html>.

Alternatively, users can download a free TFTP or HTTP server and conduct a local firmware upgrade. A free windows version TFTP server is available for download from

<http://support.solarwinds.net/updates/New-customerFree.cfm> or <http://tftpd32.jounin.net/>.

Instructions for local firmware upgrade:

1. Unzip the firmware files and put all of them in the root directory of the TFTP server.
2. Connect the PC running the TFTP server and the GXV3175 device to the same LAN segment.
3. Launch the TFTP server and go to the File menu -> Configure -> Security to change the TFTP server's default setting from "Receive Only" to "Transmit Only" for the firmware upgrade.
4. Start the TFTP server and configure the TFTP server in the phone's web configuration interface.
5. Configure the Firmware Server Path to the IP address of the PC.
6. Update the changes and reboot the GXV3175.

End users can also choose to download a free HTTP server from <http://httpd.apache.org/> or use Microsoft IIS web server.

RESTORE FACTORY DEFAULT SETTINGS

WARNING: Restoring the Factory Default Settings will **delete** all configuration information on the phone. Please **backup** or **print** all the settings before you restore to the factory default settings. Grandstream is not responsible for restoring lost parameters and cannot connect your device to your VoIP service provider.

There are two methods to restore the GXV3175 to the factory default settings.

RESTORE TO FACTORY DEFAULT SETTINGS VIA LCD MENU

The steps to restore the phone to factory default settings through the LCD menu are as follows:

Step 1: Select MENU to access the phone menu and select System Settings.

Step 2: Select Maintenance and navigate to Upgrade page.

Step 3: Select the Factory Reset option.

Step 4: Press "OK". The phone will reboot and perform a factory reset.

After factory reset, users will need to do calibration before the phone's main screen show up.

RESTORE TO FACTORY DEFAULT SETTINGS VIA THE WEB INTERFACE

Step 1: Login to the system configuration page through a web browser and select "Maintenance". From the menu on the left, select "Upgrade".

Step 2: At the bottom of the "Upgrade" page, click on the "Reset" button for Factory reset after selecting the degree of factory reset (Full Reset/User Data Reset/VoIP Data Reset).

Step 3: Click on OK to restore the phone to factory settings.



EXPERIENCING THE GXV3175 MULTIMEDIA PHONE

Please visit our website: <http://www.grandstream.com> to receive the most up- to-date updates on firmware releases, additional features, FAQs, documentation and news on new products.

We encourage you to browse our [product related documentation](#), [FAQs](#) and [User and Developer Forum](#) for answers to your general questions. If you have purchased our products through a Grandstream Certified Partner or Reseller, please contact them directly for immediate support.

Our technical support staff is trained and ready to answer all of your questions. Contact a [technical support member](#) or [submit a trouble ticket online](#) to receive in-depth support.

Thank you again for purchasing Grandstream GXV3175 Touchscreen IP Multimedia phone, it is sure to bring convenience and color to both your business and personal life.



FCC Certification Mark

WARNING

This device complies with Part 15 FCC specifications, and operation complies with the following conditions:

- (1) The device may not cause harmful interference, and
- (2) The device must tolerate any interference including interference could lead to misuse;

Any change on equipment by users without the permission will result in losing the right to use the equipment;

For a Class B digital device or peripheral, the instructions furnished the user shall include the following or similar statement, placed in a prominent location in the text of the manual.

Note: This equipment has been tested and found to comply with the limits for a Class B digital device, pursuant to part 15 of the FCC Rules. These limits are designed to provide reasonable protection against harmful interference in a residential installation. This equipment generates, uses and can radiate radio frequency energy and, if not installed and used in accordance with the instructions, may cause harmful interference to radio communications.

However, there is no guarantee that interference will not occur in a particular installation. If this equipment does cause harmful interference to radio or television reception, which can be determined by turning the equipment off and on, the user is encouraged to try to correct the interference by one or more of the following measures:

- Reorient or relocate the receiving antenna.
- Increase the separation between the equipment and receiver.
- Connect the equipment into an outlet on a circuit different from that to which the receiver is connected.
- Consult the dealer or an experienced radio/TV technician for help.

The user is cautioned that changes or modifications not expressly approved by the party responsible for compliance could void the user's authority to operate the equipment.