



We Focus • We Deliver

IP PHONE SYSTEM

CooVox Series-U100 V2

For Medium and Large Business

Quick Installation Guide

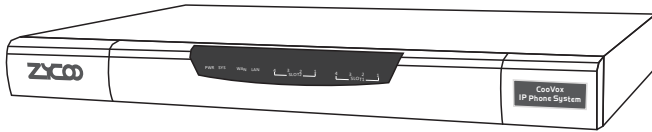

Table of Contents

1 Package Contents	03
2 Hardware Installation	04
2.1 Safety Precautions	04
2.2 Installation Tools	07
2.3 Product Installation	07
2.4 Physical Connection	12
2.5 LED Definitions	12
3 Basic System Configuration	13
3.1 Web Login	13
3.2 Network Configuration	14
3.3 Module Settings	15
4 Further Configuration	17

1 Package Contents

Thank you for purchasing ZYCOO IP Phone System. These are the items included with your IP Phone System purchase:



IP PBX



Power Cord



Quick Installation Guide



Antenna (only for GSM/WCDMA Module)



Warranty Card

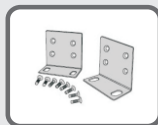

Two mounting brackets and fittings

2 Hardware Installations

The followings are instructions for setting up ZYCOO CooVox-U100 V2 IP PBX. Please refer to the illustration and follow the simple steps below to quickly install your IP phone system.

2.1 Safety Precautions

Notes:

To avoid any device damage and bodily injury caused by improper use, please obey the following rules.

- Keep the power off during the installation.
- Wear an ESD-preventive wrist strap, and make sure that the wrist strap has a good skin contact and is well grounded.
- Use only the power cord provided with IP PBX.
- Make sure that the supply voltage matches the specifications indicated on the rear panel of IP PBX.
- Confirm not to bring about the overload of power circuit before turning on the power of IP PBX, to avoid the unnecessary damage.
- To avoid the electric accident, do not open or remove the cover of IP PBX when it is working as well as off the power.
- Before cleaning the device, cut off the power supply. Do not clean it by the waterish cloth, and never use any other liquid cleaning method.

Site Requirements

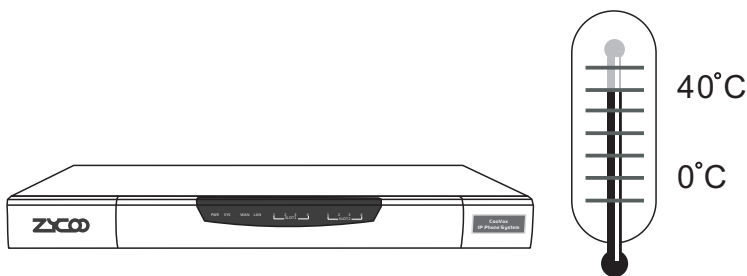

To ensure normal operation and long service life of the device, please install it in an environment that meets the requirements described in the following subsection. Please keep a proper temperature and humidity in the equipment room. Too high/low humidity may lead to bad insulation, electricity leakage, mechanical property changes and corrosions. Too high temperature may accelerate aging of the insulation materials and can thus significantly shorten the service life of the device. For normal temperature and humidity of the device, please check the following table.

Environment	Temperature	Humidity
Operating	0°C~40°C	10%~90%RH Non-condensing
Storage	-20°C~55°C	5%~95%RH Non-condensing

Clearness

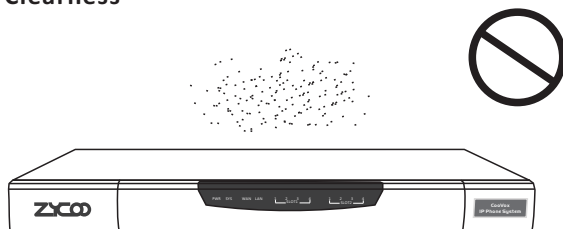

The dust accumulated on IP PBX can be absorbed by static electricity and result in poor contact of metal contact points. Some measures have been taken for the device to prevent static electricity, but too strong static electricity can cause deadly damage to the electronic components on the internal circuit board. To avoid the effect of static electricity on the operation of IP PBX, please attach much importance to the following items:

- Dust the device regularly, and keep the indoor air clean.
- Keep the device well grounded and ensure static electricity has been transferred.

Electromagnetic Interference

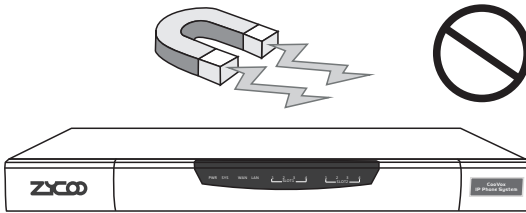

Electronic components including capacitance and inductance on the device can be affected by external interferences, such as conducted emission by capacitance coupling, inductance coupling, and impedance coupling. To decrease the interferences, please make sure to take the following measures:

- Use the power supply that can effectively filter interference from the power grid.
- Keep the devices far from high-frequency, strong-current devices, such as radio transmitting station.
- Use electromagnetic shielding when necessary.

Lightening Protection

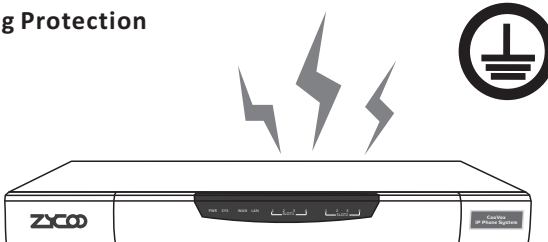

Extremely high voltage currents can be produced instantly when lightning occurs and the air in the electric discharge path can be instantly heated up to 20,000°C . As this instant current is strong enough to damage electronic devices, more effective lightning protection measures should be taken:

-
- Ensure the rack and devices are well earthed.
 - Make sure the power socket has a good contact with the ground.
 - Keep a reasonable cabling system and avoid induced lightning.
 - Use the signal SPD (Surge Protective Device) when wiring outdoor.

Note: the device is specially designed for the usage of communication operators' computer room; please obey the following requirements for installation and maintenance.

2.2 Installation Tools

- Phillips screwdriver
- ESD-preventive wrist wrap
- Cables

2.3 Product Installation

Module Installation

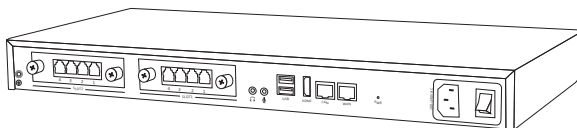

This IP PBX can support installing two extension modules at the same time.

Optional modules are as follows.

- | | | |
|----------------|-----------------|-----------------|
| ■ 4FXS Module | ■ 2GSM Module | ■ 4WCDMA Module |
| ■ 4FXO Module | ■ 4GSM Module | ■ 1PRI Module |
| ■ 2FXOS Module | ■ 2WCDMA Module | ■ 4BRI Module |

Module Combination Table

Slot1	Slot2	Feasibility
E1 Module	Vacant	No
4BRI Module		No
FXO/FXS Module		Yes
GSM/WCDMA Module		Yes
Vacant	E1 Module	Yes
	4BRI Module	Yes
	FXO/FXS Module	Yes
	GSM/WCDMA Module	Yes
FXO/FXS Module	E1 Module	Yes
	4BRI Module	Yes
	FXO/FXS Module	Yes
	GSM/WCDMA Module	Yes
GSM/WCDMA	E1 Module	Yes
	4BRI Module	Yes
	FXO/FXS Module	Yes
	GSM/WCDMA Module	Yes
E1 Module	E1 Module	Yes
	4BRI Module	No
	FXO/FXS Module	No
	GSM/WCDMA Module	No
4BRI Module	E1 Module	No
	4BRI Module	No
	FXO/FXS Module	No
	GSM/WCDMA Module	No

Below are the rules must follow to install ZYCOO module cards.

1. Please refer to module combination table to install the module/modules to the module slots, you must follow the feasible combinations or there will be problems.
2. Check if the module is clean and intact.
3. Please ensure power of IP PBX is cut off.
4. Please ensure the direction of the module is correct (ZYCOO-logo side up).
5. Push the module into the module slot through the guide rail.
6. Tighten the locking screws on the both ends of the module

Notes:

- Do not touch any device on the module, just to prevent the module from being damaged by static electricity.
- This operation must be done with power cut off. The module does not support hot-plugging.

Rack Installation

To install the device in an EIA standard-sized, 19-inch rack, follow the instructions described below:

1. Check the grounding and stability of the rack.
2. Secure the supplied rack-mounting brackets to each side of the device with supplied screws as illustrated in the following figure.

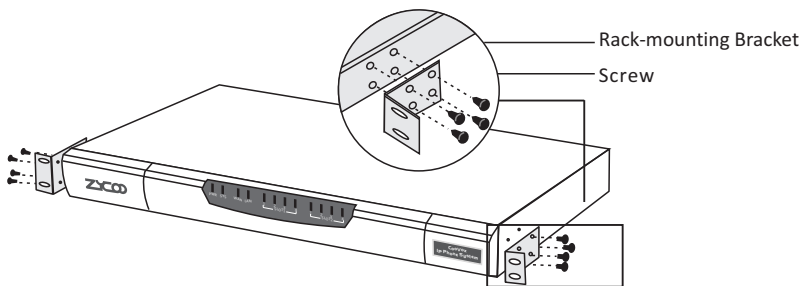

3. Install IP PBX to the right place in the rack, and then attach the brackets to the device.

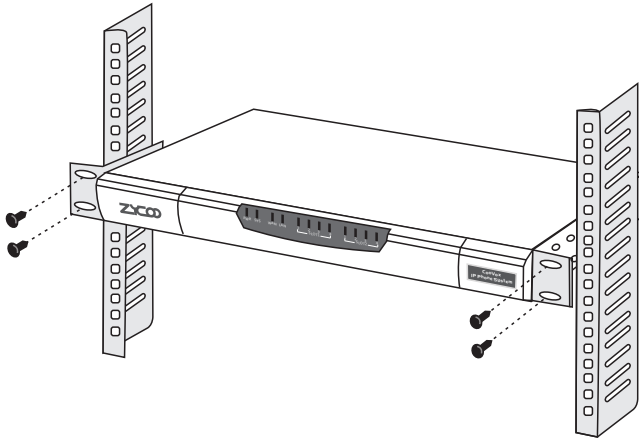

4. After the brackets are attached to the device, use suitable screws (not provided) to secure the brackets to the rack, as illustrated in the following figure.

Notes:

- Please ensure the correct installation for the grounding of the rack, which is the most important guarantee of avoiding ESD, electricity leakage, lightning, and electromagnetic interference;
- Please mount devices in sequence from the bottom to top of the rack to avoid overloading;
- Please avoid any heavy thing placed on the device to avoid any unexpected accidents;
- Please ensure heat dissipation and air circulation.

Connect to Ground

Connecting the device to ground is to quickly release the lightning over-voltage and over-current of the device, which is also a necessary measure to protect the body from electric shock.

In different environments, the device may be grounded differently. Two measures are given in the following, of which the Grounding bar is better for the protection of lightning. Users can try to choose the most appropriate measure according to different situation.

- If CooVox-U100 V2 IP PBX is installed in the computer room, and the room has dedicated Grounding bar, then the using of ground wire to connect the device with the Grounding bar is put to the first consideration as shown in the following figure.

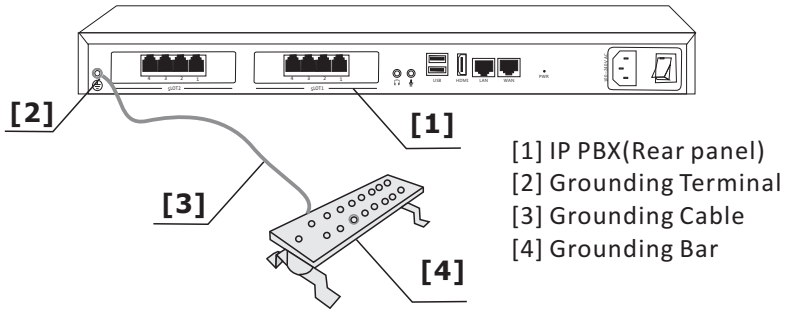

- If the device is installed in the normal environment, the device can be grounded via the PE (Protecting Earth) cable of the AC power supply as shown in the following figure.

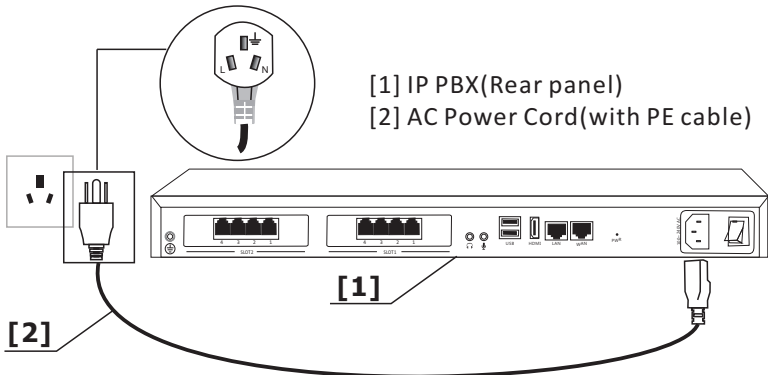

Notes:

If you intend to connect the device to the ground via the PE (Protecting Earth) cable of AC power cord, please make sure the PE (Protecting Earth) cable in the electrical outlet is well grounded in advance.

2.4 Physical Connection

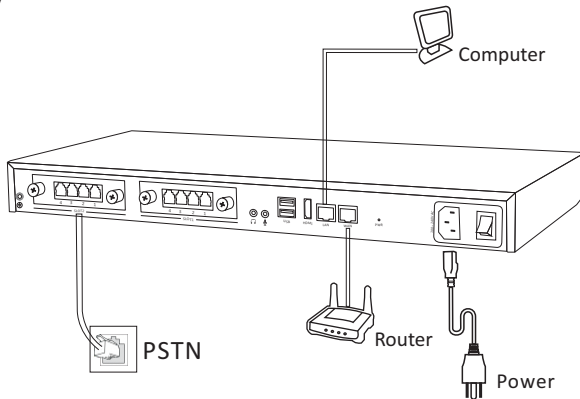

2.5 LED Definitions

Indication	Function	Status	Explanation		
PWR	Power Status	Green	Power On		
		Off	Power Off		
SYS	System Status	Wink	System is Running		
		Off	System Booting or Failed		
		Wink	Data Transmitting		
WAN/LAN	WAN/LAN Interface Status	Off	No Data Transmitting		
		Off	No Data Transmitting		
1-4(SLOT1/2)	SLOT1 and Slot2 Status	FXS	Green	Channel Loading Succeed	
			Wink	Channel Ringing	
			Off	Channel Loading Failure	
		FXO	Red	Channel Loading Succeed	
			Wink	Channel Ringing	
			Off	Channel Loading Failure	
		GSM/WCDMA	Red	Channel Loading Succeed	
			Wink	Channel Ringing	
			Off	Channel Loading Failure	
		E1/T1 (PRI/R2)	L1	Red	Module Loading Succeed
				Off	Module Loading Failure
			L2/L3	Red/Off	CPE Signaling
				Green/Off	NET Signaling
				Off/Red	SS7 Signaling
				Off/Green	R2 Signaling
			L4	Green	Connected (No Alarm)
				Red	Disconnected (Alarm)
		Red		TE Mode	
		BRI	Green	NT Mode	
			Off	Module Loading Failure	

3 Basic System Configuration

3.1 Web Login

- Step 1. Connect a PC directly to Coovox IPPBX WAN port. Change your PC IP address to 192.168.1.xx.
- Step 2. Start a web browser. To use the user interface, you need a PC with Internet Explorer (version 7.0 or higher), Firefox, Google Chrome.
- Step 3. Enter the default URL `https://192.168.1.100:9999` of the Coovox IPPBX into the browser address bar.
- Step 4. Enter the default username (admin) and password (admin). Then click “Login” to enter the Web-based user interface. Before you can see the login page you will be presented with a Certificate Error notice as below, please click “Continue to this website...” and you will be directed to the login page.

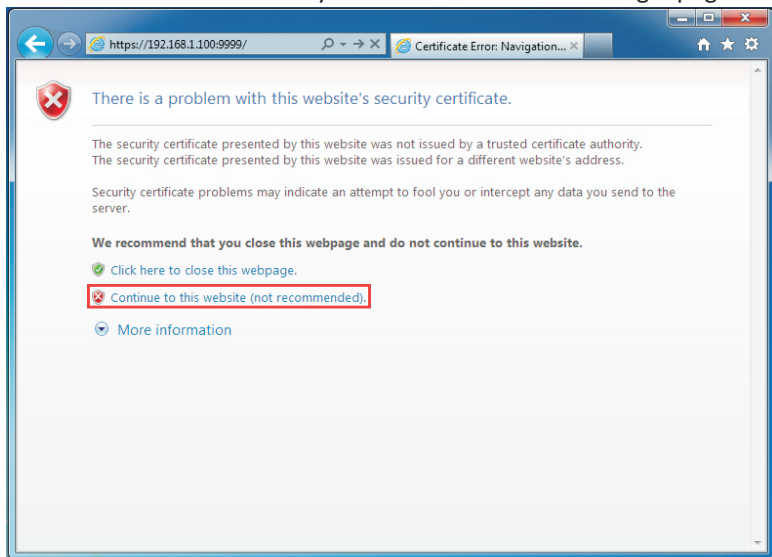

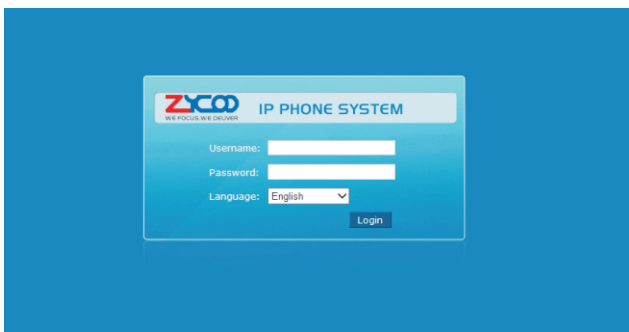

Default WAN IP address: 192.168.1.100
Default LAN IP address: 192.168.10.100
Default Username: admin
Default Password: admin

3.2 Network Configuration

Step 1. Go to Network Settings → Network

Network

IPv4 Settings IPv6 Settings VLAN Settings

WAN Port Setup

IP Assign: Static

IP Address: 192.168.1.100

Subnet Mask: 255.255.255.0

Gateway: 192.168.1.1

Primary DNS: 8.8.8.8

Alternative DNS: 8.8.4.4

LAN Port Setup

IP Address: 192.168.10.100 Subnet Mask: 255.255.255.0

IP AddressV1: Subnet MaskV1:

IP AddressV2: Subnet MaskV2:

Save Cancel

Step 2. Configure the network information

There are three types of network connection. They are Static, DHCP, PPPoE(Point-to-Point Protocol over Ethernet). You can find detail settings in the user manual.

WAN Port Setup	
IP Assign:	Static ▾
IP Address:	192.168.1.100
Subnet Mask:	255.255.255.0
Gateway:	192.168.1.1
Primary DNS:	8.8.8.8
Alternative DNS:	8.8.4.4

3.3 Module Settings

If you have FXS/FXO/GSM/WCDMA modules installed on CooVox-U100 V2 IPPBX system then you don't have to configure the module settings, because that's default module settings for the CooVox-U100 V2 IPPBX system.

SLOT 1	
Module Type:	FXS/FXO/GSM/WCDMA ▾

SLOT 2	
Module Type:	FXS/FXO/GSM/WCDMA ▾

If you have installed E1 or BRI module please do the following configurations.

Go to System->Module Settings

If E1 module:

SLOT 2

Module Type: E1/T1 ▼
E1/T1 Settings:
Mode: E1 ▼
Signaling: CPE ▼
Framing: CCS ▼
Coding: HDB3 ▼
CRC4:

If BRI module:

SLOT 2

Module Type: ISDN BRI ▼
BRI Settings:
Type of Port 1: TE_PTP ▼
Type of Port 2: TE_PTP ▼
Type of Port 3: TE_PTP ▼
Type of Port 4: TE_PTP ▼

Save the configurations and confirm to reboot the IPPBX system.

4 Further Configuration

Thank you for the purchase of ZYCOO products. The above steps introduce simple configuration for CooVox – U100 V2. For further configuration, please refer to the user manual. If you have other questions, please contact the local dealer or distributor from which you purchased this product.

You can also browse our online FAQ resource at the ZYCOO Web site first to check if it could solve your issue. If you need more support, please contact ZYCOO support team.

ZYCOO online FAQ:

[Http://www.zycoo.com/support](http://www.zycoo.com/support)

Support team mail address:

support@zycoo.com

Copyright © Zycoo Co., Ltd. 2016

The logo for ZYCOO, featuring the letters ZYCOO in a bold, stylized, sans-serif font. The letters are interconnected, with the 'Y' and 'C' sharing a vertical stroke, and the 'O's being circular and touching each other and the 'C'.

We Focus • We Deliver