

VXi BlueParrott® Point™ User Guide



TABLE OF CONTENTS

Safety Information	3	Advanced Features and Functions.....	14
Package Contents.....	4	• Multiple Device Pairing	
Glossary of Terms	5	• Multipoint Mode	
Headset Overview.....	6	• Additional Features and Functions	
Charging the Headset	7	– Last Number Redial	
• Battery Power Indicators		– Call Waiting/Rejecting a Call	
• Operation While Using the Charger/Adapter		– Rejecting a Call	
		– Phone Voice Control (e.g. Siri® or Google Now™)	
		– Muting	
		– Transferring Audio	
		– Turning Headset Indicator Lights On/Off	
Getting Started	9	• Resetting Headset Paired Devices List	
• On/Off/Standby			
• Pairing with a Phone			
– NFC (One-Touch) Pairing			
– Regular Pairing			
• Wearing and Adjusting the Point			
• Making/Taking Calls			
		Functions & Indicators Table	18

SAFETY INFORMATION

IMPORTANT SAFETY NOTE: Prolonged exposure to high volume levels can damage your hearing. To avoid injury, set the volume to the lowest comfortable level. If you experience ringing in your ears, or voices sound muffled, stop using the headset. Avoid turning up the volume to block noisy surroundings. It's possible for your ears to adapt to volume that is too high, and this could result in permanent hearing damage without any noticeable discomfort.

- Check with local and state laws regarding cell phone/headset usage while operating a motor vehicle.
- Do not immerse any part of this product in water.
- Plastic bags and small parts may cause choking if ingested. Keep them away from small children and pets.
- Use only the power cords included with this product.
- Avoid temperatures exceeding 140° F (will cause equipment failure).

PACKAGE CONTENTS

1. BlueParrott® Point™ Headset
2. Choice of Ear Buds (multiple sizes)
3. Choice of Ear Hooks (multiple sizes)
4. USB Charging Cable
5. Quick-Start Guide*
6. Warranty and Compliance Insert*

*Not pictured.

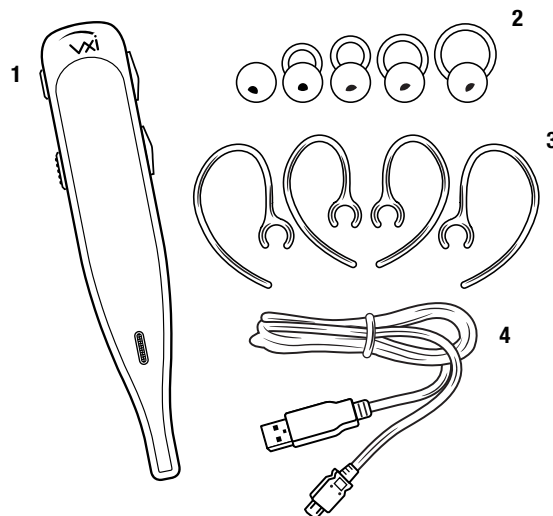

Images are not shown to scale.

GLOSSARY OF TERMS

- **On:** Headset is on, but there is no connection to the phone (red light will flash).
- **MFB:** Abbreviation for “Multifunction Button.”
- **Multipoint Mode:** Multipoint Mode allows you to connect and switch between two Bluetooth devices.
- **Paired:** Two Bluetooth devices agree to communicate with one another.
- **Standby Mode:** Headset is on, Bluetooth link is active, and the user is not on a call (blue light will flash).
- **Talk Mode:** Headset is in use with the cell phone while the cell phone is on an active call (blue light will flash).

HEADSET OVERVIEW

- A.** Volume Up/Mute
- B.** Volume Down
- C.** Microphone Boom
- D.** On/Off Switch
- E.** Indicator Lights
- F.** Multifunction Button (MFB)
- G.** NFC Zone (pictured below)

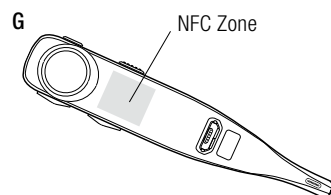
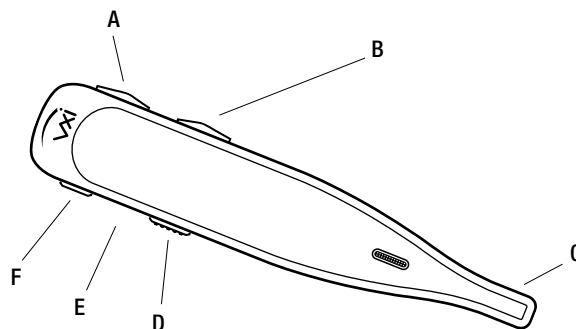

CHARGING THE HEADSET

Connect the USB charger cord into the headset's USB charging port. If the headset is *not* fully charged, the indicator will turn red. When the indicator turns blue and *stays* blue, the unit is fully charged. A *fully* discharged battery will need approximately 1.5 hours to achieve a complete charge.

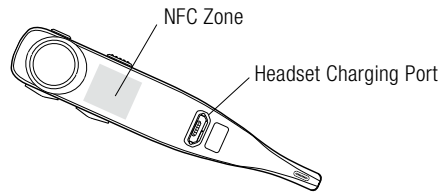

Battery Power Indicators

While charging, the indicator light shows the level of battery power on your Point as follows:

Blue light: Fully charged. Over 6 hours' talk time.

Red light: Less than a full charge.

For best performance, keep charging the headset when not in use.

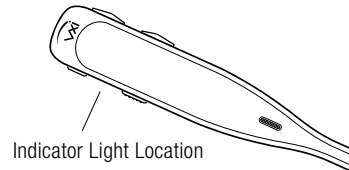

CHARGING THE HEADSET (continued)

Operation While Using the Charger/Adapter

The Point headset should be operated from battery power only. If you connect the headset to a charger while it is turned on, it will reset and shut off. To turn it back on again, first unplug the headset from the USB charging cord, slide the switch to the "off" position (if not already done), then back to the "on" position.

NOTE: Do not attach the charger mid-call. This will cause the headset to reset, and the call will be sent back to the phone.

GETTING STARTED

On/Off/Standby

Turn Headset On: Slide the switch down towards the boom to expose a green bar in the switch cavity. The LED will flash blue three times and you will hear a voice prompt, "Power on."

Turn Headset Off (conserves battery power): Slide the switch up towards the back of the headset to expose a red bar in the switch cavity. The LED will flash red four times and you will hear a voice prompt, "Power off."

Standby Mode: Once the headset is turned on (after the initial pairing), it will attempt to connect to the last device that it was paired with, putting itself into Standby Mode.

Pairing with a Phone

NFC (One-Touch) Pairing

1. Confirm that your cell phone is NFC-capable.
2. Make sure that NFC is enabled on your cell phone.
3. Turn the headset on.
4. Place the NFC zone of your cell phone against the NFC zone of the headset and hold together while your cell phone registers the headset.
5. Follow the prompts on your cell phone until it confirms pairing is successful.

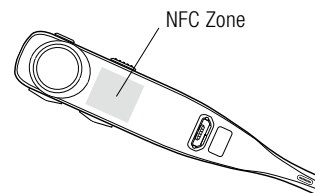

Note: NFC and One-Touch Pairing are dependent on your cell phone. The size and sensitivity of your phone's NFC zone and how to connect the headset may vary between devices.

GETTING STARTED (continued)

Manual Pairing

Placing Headset into Pairing Mode

When you turn the headset on for the first time, or if its pairing memory has been wiped clear, it will go into pairing mode automatically. If the headset has already been paired with another device, you will need to manually put it into pairing mode if you are not going to use NFC Pairing.

Power on the headset, then press and hold the MFB for approximately 6 seconds until you hear the audio prompt "Discovering." The headset will be visible for pairing to devices for 120 seconds.

Pairing to a Cell Phone

1. Make sure that other Bluetooth devices are turned off or out of range.
2. Place the headset into pairing mode.
3. Put your cell phone in Bluetooth Search/Scan Mode per the manufacturer's instructions.
4. Select "VXi Point" to pair. (Passcode is "0000" if needed.)
5. When connected, the headset will give you the voice prompt, "Your headset is connected" and the indicator light will flash blue.

GETTING STARTED (continued)

Wearing and Adjusting the Point

The headset is provided with the medium-loop ear bud already attached. If you need to change it, peel it off and replace with the ear bud of your choice.

Choose the ear bud and ear hook (if desired) that best fits your ear.

The headset can be worn on either ear, with or without the ear hook. The ear hooks are left and right specific and are marked with an "L" for left or "R" for right to show which side they are for.

To attach an ear hook, clip the "C" of the hook over the neck of the receiver.

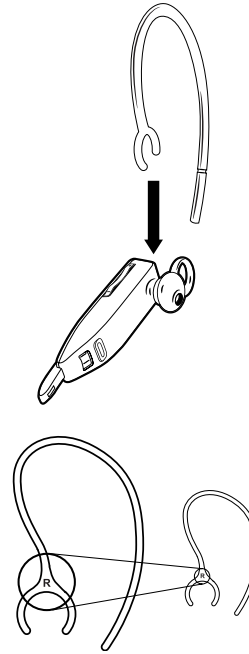

GETTING STARTED (continued)

When wearing your Point, adjust the fit by rotating the ear bud so that the stabilizer loop (if applicable) presses against the back curve of your ear. Make sure that the boom is pointing towards the corner of your mouth.

To get the best performance from our noise-canceling technology, angle the microphone boom towards the corner of your mouth. Positioning is important; small adjustments in microphone placement can improve performance.

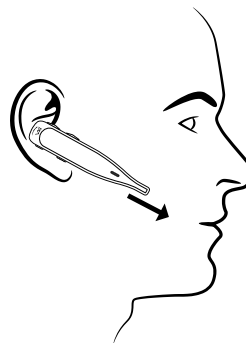

GETTING STARTED (continued)

Making/Taking Calls

The headset must be on and connected with your phone.

Making a Call

1. Dial the desired number on your phone. You will hear the call in the headset.
2. To end the call, press the MFB once. The call will end and the headset will enter standby mode.

Answering a Call

1. When you receive a call, you will hear ring tones in the headset. Press the MFB once to answer the call.
2. To end the call, press the MFB once. The call will end and the headset will enter standby mode.

Rejecting an Incoming Call

1. To reject an incoming call, press and hold the MFB for two seconds. You will hear a two-note descending tone and the call will be transferred to your voicemail (if available).

ADVANCED FEATURES AND FUNCTIONS

Multiple Device Pairing and Multipoint Mode

The Point has pairing memory for up to 8 devices. The headset can also use Multipoint Mode, which means that it can be connected to two Bluetooth devices at the same time. You do not have to do anything to enable Multipoint Mode.

Using the Point in Multipoint Mode

1. To use the headset in Multipoint Mode, first make sure the headset is paired with both your devices.
2. With both devices in range and with their Bluetooth enabled, turn the headset on.
3. As each Bluetooth device connects to the headset, you will hear the voice prompt, "Your headset is connected."

The Point will monitor both phones and enable you to answer a call on either one from the headset.

If you are on a call and the other device receives a call, you will hear a notification in the headset.

ADVANCED FEATURES AND FUNCTIONS (continued)

Additional Features and Functions

i. Last Number Redial

To redial the last number that was dialed from the cell phone, press and hold the Volume Down button for approximately 1 second. A beep will be heard and the phone will redial the last number.

ii. Call Waiting/Rejecting a Call

If you are on an active call and a second call comes in, you will hear a low tone notification in the headset. If supported by your phone, you have the following options:

- **To accept the incoming call and end the active call**, press the MFB once to end, and then once again to answer.
- **To accept the incoming call and place the active call on hold**, quickly press the MFB twice.
- **To reject the incoming call**, quickly press both the MFB and Volume Down button simultaneously.

iii. Rejecting a Call

To reject an incoming call when not on another call, press and hold the MFB for 1-2 seconds.

iv. Phone Voice Control (e.g. Siri® or Google Now™)

Press the MFB once while the headset is in standby mode to initiate voice command functions on your phone. Support for this is phone dependent. See your phone's user guide for more information.

ADVANCED FEATURES AND FUNCTIONS (continued)

v. Muting

The Point can be muted while on a call by pressing and holding the Volume Up button for 1-2 seconds. A single tone will sound as mute is engaged.

To unmute, press and hold the button again for 1-2 seconds.

While muted, a reminder tone will sound every 10 seconds.

vi. Transferring Audio

To transfer audio from the headset to the cell phone while on a call, press and hold the Volume Down button for 1-2 seconds. The audio will transfer to the phone. Repeat to transfer audio back to the headset. When audio is transferred to the phone, the light on the headset will be off until audio is transferred back to the headset.

vii. Turning Headset Indicator Lights On/Off

A *quick* press of the Volume Up and Volume Down buttons *together* will turn the headset indicator lights off. Repeat to turn the indicator lights on. When powering on the headset, the indicator lights will be in the same state as they were when last powered off.

ADVANCED FEATURES AND FUNCTIONS (continued)

Resetting Headset's Paired Devices List

This will reset or clear the headset's internal paired devices list. The headset must be on to perform this function.

1. Power on the headset. It does not matter if it connects to any devices.
2. Hold the headset near your ear and press and hold the Volume Up and the Volume Down buttons *together* for approximately 6-10 seconds until two low tones are heard. The LED will flash red two times, then the headset will automatically go into Pairing Mode.
3. If you are not ready to pair the headset with a device, power it off. The pairing memory is now clear and will need to be paired to any desired devices before it can be used with them.

FUNCTIONS & INDICATORS TABLES

Standby Mode Functions

Function	Button/Duration of Press	LED Indicator	Audio Indicator	Voice Indicator
Power On	Slide switch towards boom	3 fast blue flashes	NONE	"Power on"
Power Off	Slide switch towards tail	4 fast red flashes	NONE	"Power off"
Enable Pairing Mode	MFB (5-6 seconds)	Alternating red and blue flash	NONE	"Discovering"
Volume Up	Volume Up (quick press)	NONE	1 short tone	NONE
Volume Down	Volume Down (quick press)	NONE	1 short tone	NONE
Phone Voice Control (Start/End)	MFB (quick press)	NONE	1 tone	NONE
Last Number Redial	Volume Down (1-2 seconds)	NONE	1 short tone	NONE
Disable LEDs	Volume Up/Volume Down (quick press)	NONE	1 short tone	NONE
Enable LEDs	Volume Up/Volume Down (quick press)	LEDs active	1 short tone	NONE

FUNCTIONS & INDICATORS TABLES (continued)

Standby Mode Functions (continued)

Function	Button/Duration of Press	LED Indicator	Audio Indicator	Voice Indicator
Reset Paired Devices	Volume Up/Volume Down (5-6 seconds)	2 fast red flashes	2 low tones	NONE
Disable Multipoint Mode	MFB/Volume Up & Volume Down (3-4 seconds)	NONE	4 falling tones	NONE
Enable Multipoint Mode	MFB/Volume Up & Volume Down (quick press)	NONE	4 rising tones	NONE
Establish Service Level Connection	MFB (quick press)	Fast blue flash	1 long tone	"Your headset is connected"

FUNCTIONS & INDICATORS TABLES (continued)

In-Call Functions

Function	Button/Duration of Press	LED Indicator	Audio Indicator	Voice Indicator
Volume Up	Volume Up (quick press)	NONE	1 short tone	NONE
Volume Down	Volume Down (quick press)	NONE	1 short tone	NONE
Mute (On/Off)	Volume Up (1-2 seconds)	NONE	1 tone	NONE
Mute Reminder	NONE	NONE	1 tone (every 10 seconds)	NONE
Answer a Call	MFB (quick press)	Blue light flashes slightly slower	2 rising tones	NONE
End a Call	MFB (quick press)	Blue light flashes slightly faster	2 falling tones	NONE
Reject a Call*	MFB (1-2 seconds)	NONE *Sends call to voicemail (if available)	2 falling tones	NONE

FUNCTIONS & INDICATORS TABLES (continued)

In-Call Functions (continued)

Function	Button/Duration of Press	LED Indicator	Audio Indicator	Voice Indicator
Transfer Audio	Volume Down (1-2 seconds)	NONE (LEDs go out until call ends, or audio is transferred back to the headset)	1 long tone	NONE
Answer Incoming Call, Hold Current Call	MFB (2 quick presses)	NONE	NONE	NONE
Answer Incoming Call, End Current Call	MFB (quick press)	NONE	NONE	NONE
Reject Incoming Call, Continue Current Call	MFB & Volume Down (quick press)	NONE	2 falling tones	NONE

FUNCTIONS & INDICATORS TABLES (continued)

Notifications

Notification	Button/Duration of Press	LED Indicator	Audio Indicator	Voice Indicator
Mute Reminder	NONE	NONE	1 tone (every 10 seconds)	NONE
Headset Connects to Device	NONE	Blue light, fast flash	NONE	"Your headset is connected"
Disconnect from Device	NONE	Red light, slow flash	NONE	"Your headset is disconnected"
Out of Range (Link Loss)	NONE	Red light, slow flash	1 short tone	NONE
Low Battery	NONE	Red light, 2 fast flashes	NONE	"Battery low" every 60 seconds
Connect A2DP	NONE	Blue MFB (quick, double-flash)	NONE	"Your headset is connected"