

Simply IP Phone SIP-T18P



Quick Installation



www.yealink.com

Packing List

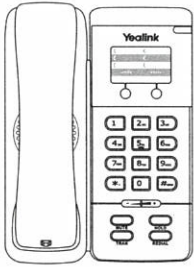

IP Phone



Handset

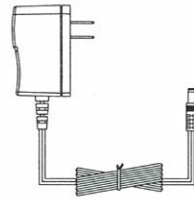

Power Adapter

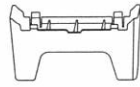

Stand



Ethernet Cable

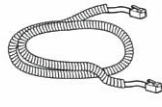

Handset Cord



CD Content

2. Connect Handset, shown as below:

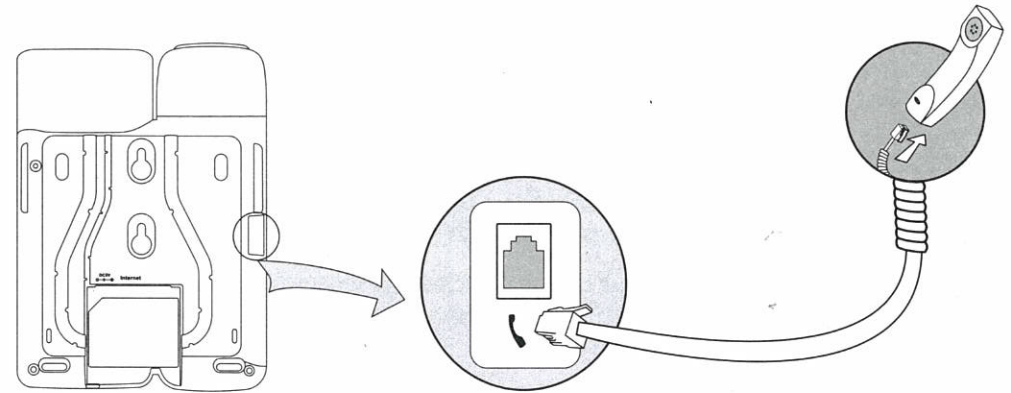

Assembling the Phone

1. Attach the Stand, shown as below:

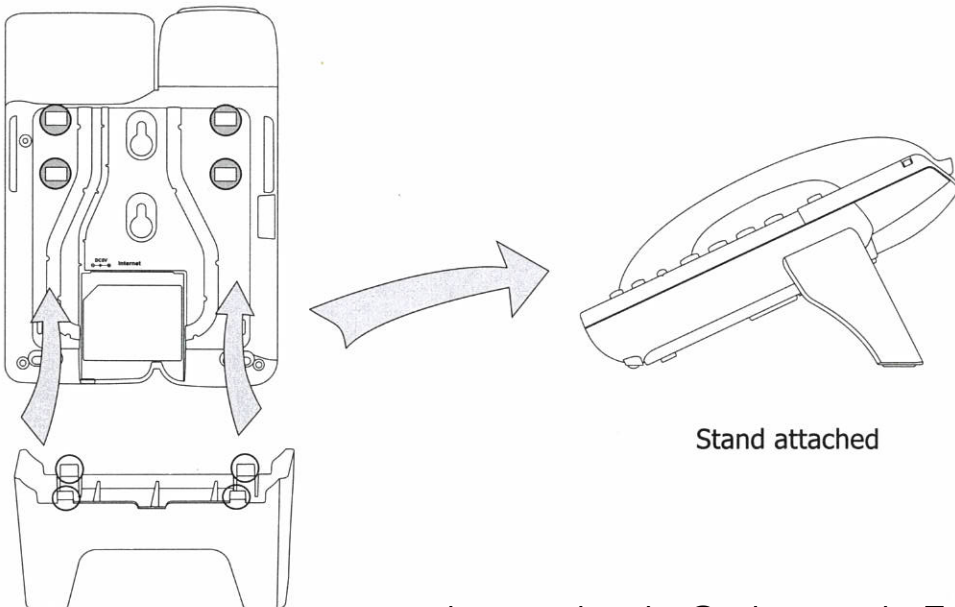

3. Connect Network and Power

You can connect the phone to the AC Power directly by the power adapter. Shown as below:

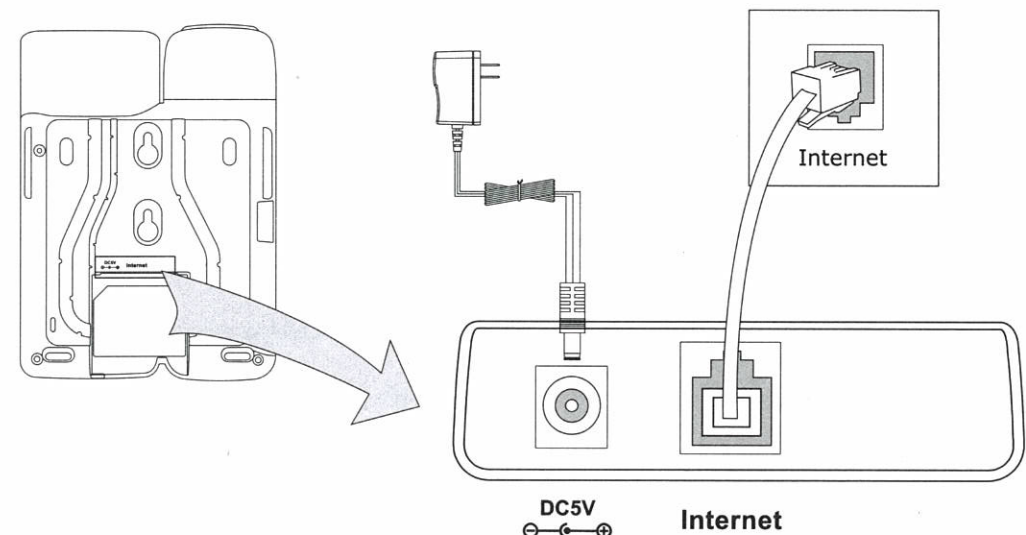

Configuring via Web Page

Pick up the handset and dial *****90#** to get the IP address of by voice prompt. Then enter it (for example <http://192.168.3.35>) into the address bar of web browser.

The default login name and password are **admin/admin**.

Note: Please locate your PC in the same network segment of the IP phone(192.168.3.X) to access the web configuration page. Please consult your network administrator or service provider for help.

Network Settings: Choose Network->Internet Port (WAN)

DHCP: By default the phone attempts to contact to a DHCP Server in your network in order to obtain its valid network settings, e.g. IP address, sub mask, gateway, DNS server, etc.

Static IP Address: If your phone cannot contact a DHCP Server for any reason, you need to enter the network settings manually via Static IP Address. Please contact your internet administrator for more details.

Note: Using the wrong network parameters may result in inaccessibility of your phone and may also have an impact on your network performance! Please contact your network administrator!

Account Setting: Choose Account

Parameter:

Account Active: You can Enable/Disable this account by the right/ left navigation key respectively.
Display Name: It is showed as Caller ID when making a phone call.
Register Name: It is provided by ISP for registration.
User Name: User account information, provided by VoIP service provider.
Password: It is provided by ISP for registration.
SIP Server: Server for registration, provided by ISP.

Please contact your service provider for more account details.

Network Configuring via Keypad

DHCP: Pick up the handset and dial *****88#**, follow the prompt to enter the **"0#"** to disable the DHCP, or **"1#"** to enable it.

Static IP:

- 1) IP Address: Pick up the handset and dial *****80#**, then follow the prompt to enter the IP address and press the # key to confirm (for example:192.168.1.56#).
- 2) Subnet Mask: Pick up the handset and dial *****81#**, then follow the prompt to enter the Subnet Mask and press the # key to confirm (for example:255.255.255.0#).
- 3) Gateway: Pick up the handset and dial *****82#**, then follow the prompt to enter the gateway and press the # key to confirm (for example:192.168.1.0#).
- 4) DNS1: Pick up the handset and dial *****83#**, then follow the prompt to enter the DNS1 and press the # key to confirm (for example:202.101.103.55#).
- 5) DNS2: Pick up the handset and dial *****84#**, then follow the prompt to enter the DNS2 and press the # key to confirm (for example:202.101.103.55#).

You can refer to the above "Configuring via Web Page" for the parameter details.

The manual is only for reference, please take the object as the standard.

We reserve the right to improve or change the product and the user guide without notice. V0.1